

MATERIAL:

HOUSING: LCP,UL94V-0,BLACK.HF.
 TERMINALS BRACKET: LCP,UL94V-0,BLACK.HF.
 SHIELD: C2680,T=0.20MM,NICKEL PLATING ON ALL AREA.
 TERMINAL: PHOSPHOR BRONZE C5191,T=0.35MM,
 30U" GOLD PLATING ON CONTACT AREA.

MECHANICAL:

DURABILITY: 750 CYCLES MIN.
 MATING FORCE: 23N MAX.
 OPERATING TEMPERATURE: -40°C~+85°C.
 STORAGE TEMPERATURE: -40°C~+85°C.
 ALL CRITICAL DIMENSIONS WITH "*"

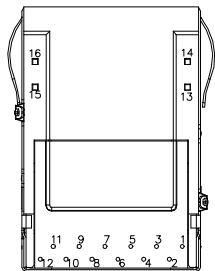
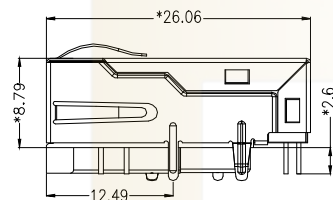
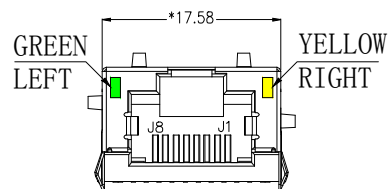

			GENERAL TOLERANCE	制图 DRAWING	深圳市华灿天禄电子有限公司 ShenzhenhuacantianluELECTRONICS CO.,LTD			
			DIM TOL	审核 CHECK	产品名称 TITLE	网络插座 (插件 沉板2.6 左绿右黄带弹 TAB-UP 1X1 1000BASE)	版本 REV.	A
			X.X ±0.30	批准 APPROVAL	产品料号 PART NO.	HC911025C-M926-A-LGRY	单位 UNITS	mm
1	初版发行		X.XX ±0.20	比例 SCALE	投影 Projection		页次 SHEET	1/4
			X.XXX ±0.10	Angle ±3.0°	材料 MATERIAL			
序号 No.	变更内容 MODIFY CONTENT	日期 MODIFY DATE						

Suggested Panel Opening:

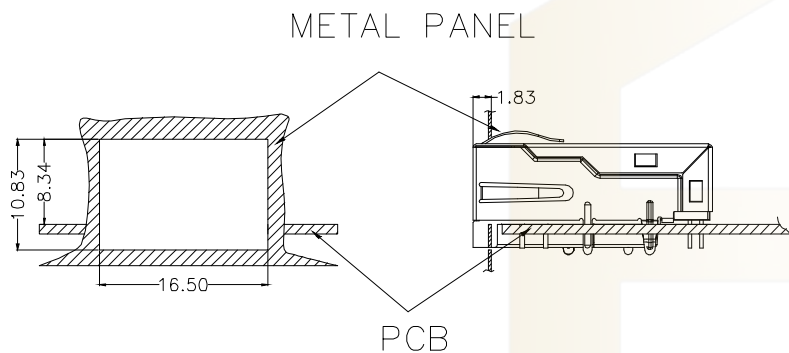

UNIT:mm / inch
Tolerances: ± 0.10 / 0.004

Keep-Out Area (Component Side View):

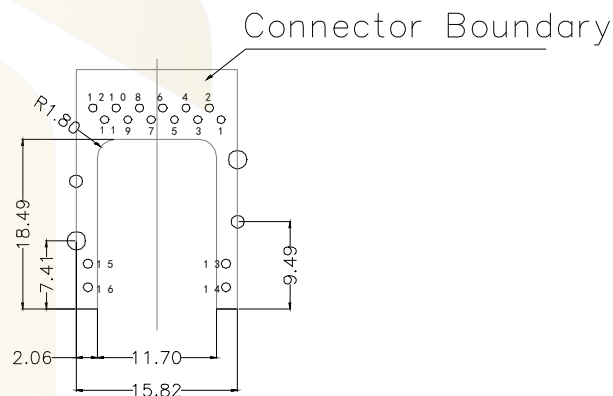

Plug In Side

UNIT:mm / inch
Tolerances: ± 0.10 / 0.004

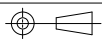
			GENERAL TOLERANCE	制图 DRAWING	 深圳市华灿天禄电子有限公司 ShenzhenhuacantianluELECTRONICS CO.,LTD			
			DIM TOL	审核 CHECK				
			X.X ± 0.30	批准 APPROVAL	产品名称 TITLE	网络插座 (插件 沉板2.6 左绿右黄带弹 TAB-UP 1X1 1000BASE)	版本 REV.	A
1 初版发行			X.XX ± 0.20	比例 SCALE	产品料号 PART NO.	HC911025C-M926-A-LGRY	单位 UNITS	mm
序号 No.	变更内容 MODIFY CONTENT	日期 MODIFY DATE	Angle $\pm 3.0^\circ$	投影 Projection		材料 MATERIAL	页次 SHEET	1/4

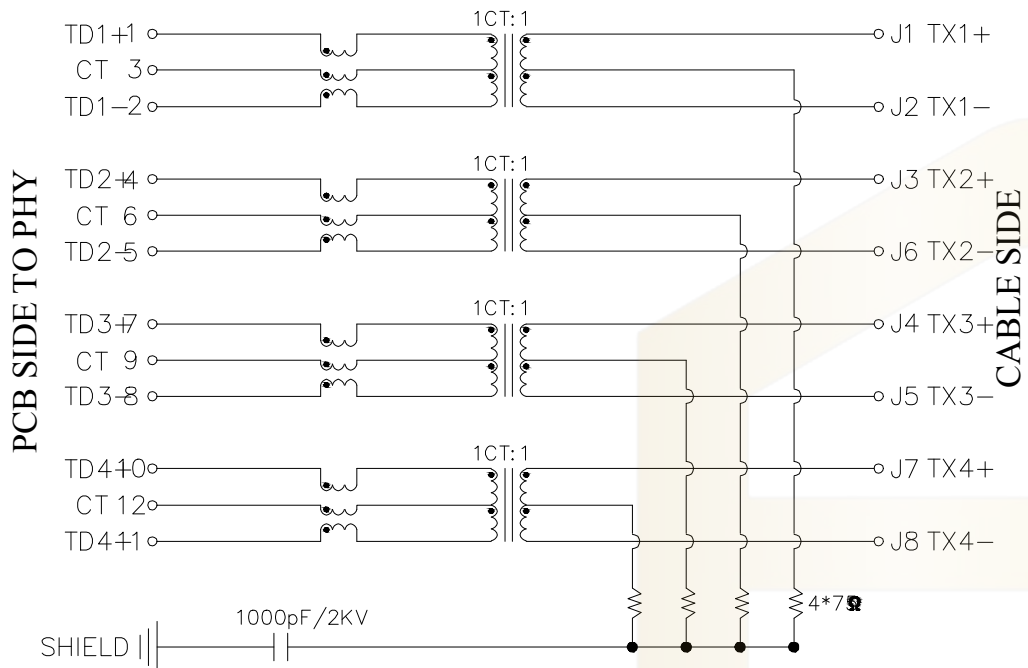

Electrical:

1. Turn ratio: 1~2: J1~J2=1CT:1CT(±2%).
4~5: J3~J6=1CT:1CT(±2%).
7~8: J1~J2=1CT:1CT(±2%).
10~11: J3~J6=1CT:1CT(±2%).
2. OCL: 350uH Min. at 100KHz 100mV 8mA DC.
3. Insertion Loss: -1.0 dB Max 1~100MHz.
-1.2 dB Max 100~125MHz.
4. Return loss: -16dB Min 1~40MHz;
-12dB Min 40~60MHz.
-10dB Min 60~80MHz.
-8dB Min 80~100MHz.
5. Cross talk: -30dB Min 1~100MHz;
6. CMR: -30dB Min 1~100MHz;
7. Hi-Pot: 2250V DC 6S 1mA PRI TO SEC

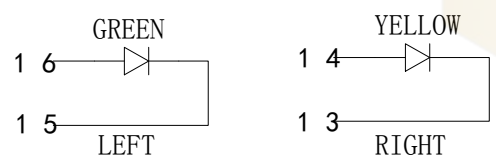

LED Specification

Standard LED Color	LED Wavelength	Foward(A)	Foward(V)
Green	568nm	20mA	1.85-2.45V
Yellow	568nm	20mA	1.7-2.2V

			GENEERL TOLERANCE	制图 DRAWING	深圳市华灿天禄电子有限公司 ShenzhenhuacantianluELECTRONICS CO., LTD			
			DIM TOL	审核 CHECK	产品名称 TITLE	网络插座 (插件 沉板2.6 左绿右黄带弹 TAB-UP 1X1 1000BASE)	版本 REV.	A
			X.X ±0.30	批准 APPROVAL	产品料号 PART NO.	HC911025C-M926-A-LGRY	单位 UNITS	mm
			X.XX ±0.20	比例 SCALE	材料 MATERIAL		页次 SHEET	1/4
			X.XXX ±0.10	投影 Projection				
			Angle ±3.0°					
序号 No.	变更内容 MODIFY CONTENT	日期 MODIFY DATE						
1	初版发行							

PROFILE OF WAVE SOLDER

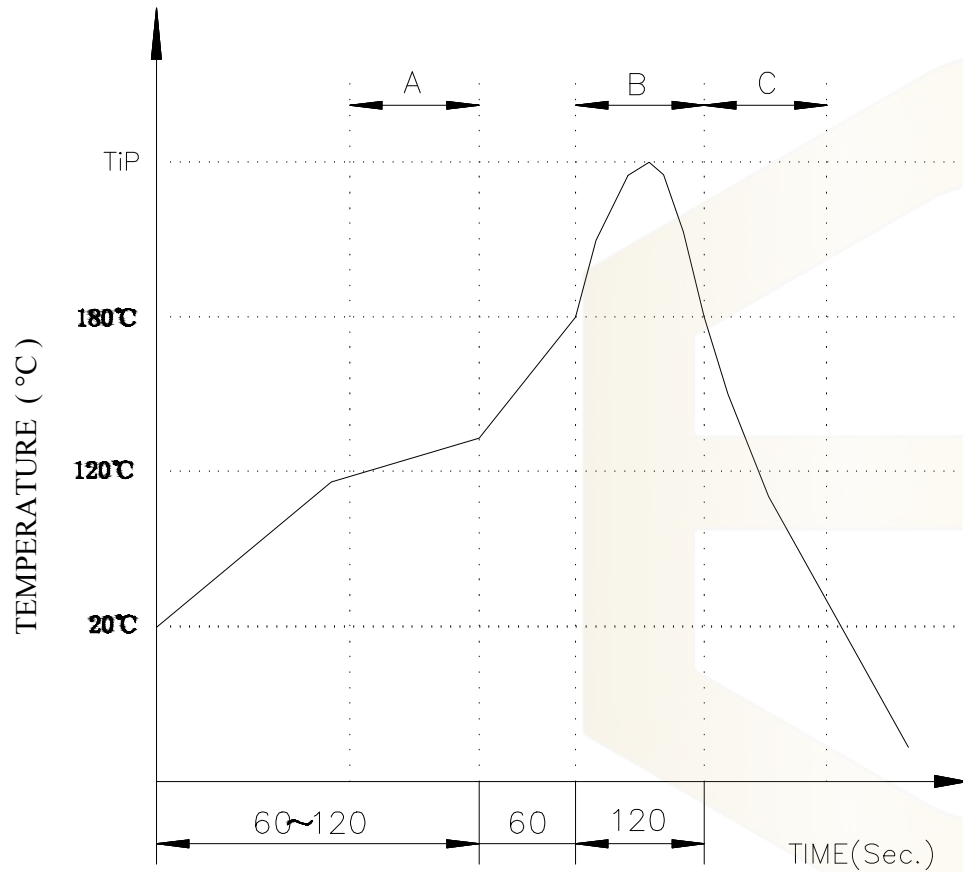

A.Preheating B.Soldering C.Gradual Cooling
 Tip temperature:260°C.
 Tip temperature time:5Sec Max.
 Tip melting point of Sn96.5/Ag3/Cu0.5:217°C.

Remarks: after wave soldering, the plastic positioning columns of the product which under the PCB will be slightly melted, but it won't affect its function.

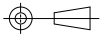
			GENERAL TOLERANCE	制图 DRAWING	 深圳市华灿天禄电子有限公司 ShenzhenhuacantianluELECTRONICS CO.,LTD			
			DIM TOL	审核 CHECK				
			X.X ±0.30	批准 APPROVAL	产品名称 TITLE	网络插座 (插件 沉板2.6 左绿右黄带弹 TAB-UP 1X1 1000BASE)	版本 REV.	A
1 初版发行			X.XX ±0.20	比例 SCALE	产品料号 PART NO.	HC911025C-M926-A-LGRY	单位 UNITS	mm
序号 No.	变更内容 MODIFY CONTENT	日期 MODIFY DATE	Angle ±3.0°	投影 Projection		材料 MATERIAL	页次 SHEET	1/4