

MATERIAL:
 HOUSING : PBT,UL94V-0,BLACK.
 TERMINALS BRACKET: PBT,UL94V-0,BLACK.
 SHIELD: C2680,T=0.20MM,NICKEL PLATING ON ALL AREA.
 TERMINAL: PHOSPHOR BRONZE C5210,T=0.35MM,
 6U" GOLD PLATING ON CONTACT AREA.

MECHANICAL:
 DURABILITY : 750 CYCLES MIN.
 MATING FORCE : 23N MAX.
 OPERATING TEMPERATURE: -40°C~+85°C.
 STORAGE TEMPERATURE: -40°C~+85°C.
 ALL CRITICAL DIMENSIONS WITH "**"

		GENREL TOLERANCE		制图	深圳市华灿天禄电子有限公司		
				DRAWING	ShenzhenhuacantianluELECTRONICS CO.,LTD		
		DIM	TOL	审核	产品名称	网络插座 (插件 TAB-DOWN 1X1	版本
		X.X	± 0.30	CHECK	TITLE	1000BASE 带灯带弹 脚长2.5)	REV.
		X.XX	± 0.20	批准	产品料号	HC911130C-M921-A-F25	A
		X.XXX	± 0.10	APPROVAL	PART NO.		单位
1	初版发行	Angle	$\pm 3.0^\circ$	投影	MATERIAL		mm
序号	变更内容	日期		投影			页次
No.	MODIFY CONTENT	MODIFY DATE		Projection			SHEET

RECOMMENDED PANEL CUTOUT(REFERENCE ONLY):

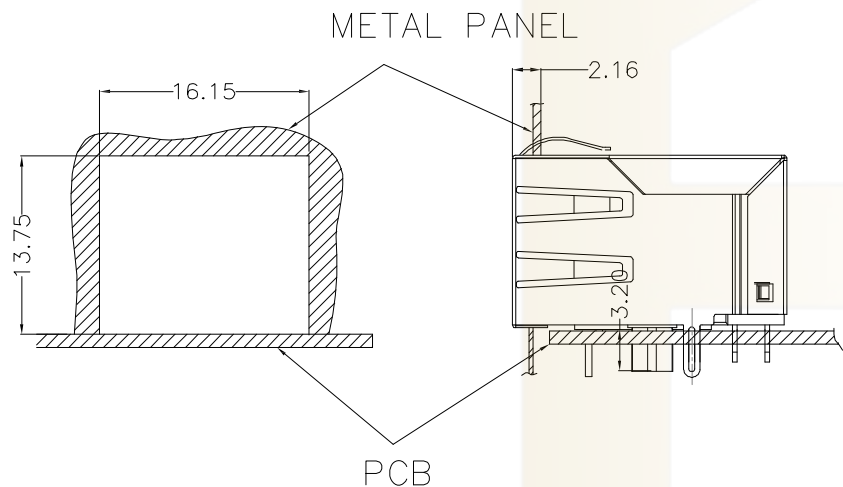

UNIT: MM / INCH
TOLERANCES: ± 0.10 / 0.004
REFERENCE ONLY

KEEP-OUT AREA(COMPONENT SIDE VIEW):

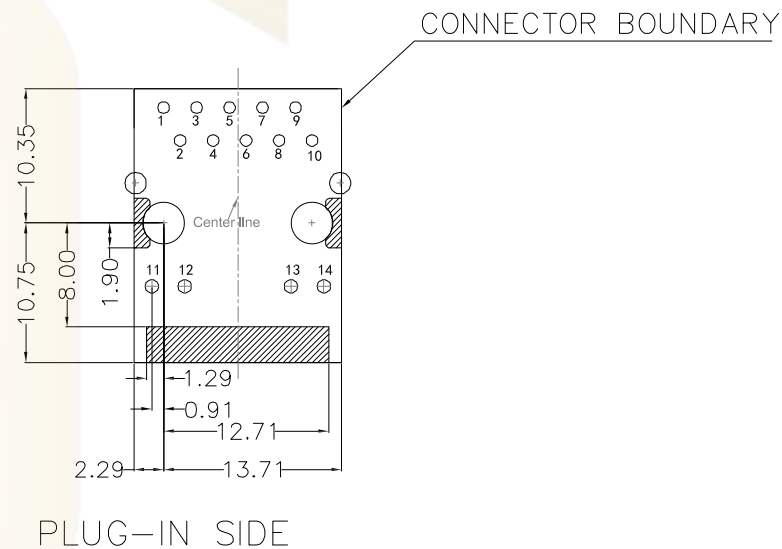

UNIT: MM / INCH
TOLERANCES: ± 0.10 / 0.004

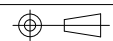
			GENREL TOLERANCE	制图 DRAWING	 深圳市华灿天禄电子有限公司 ShenzhenhuacantianluELECTRONICS CO.,LTD			
			DIM TOL	审核 CHECK				
			X.X ± 0.30	批准 APPROVAL	产品名称 TITLE	网络插座 (插件 TAB-DOWN 1X1 1000BASE 带灯带弹 脚长2.5)	版本 REV.	A
			X.XX ± 0.20	比例 SCALE	产品料号 PART NO.	HC911130C-M921-A-F25	单位 UNITS	mm
			X.XXX ± 0.10	投影 Projection	材料 MATERIAL		页次 SHEET	2/4
1	初版发行		Angle $\pm 3.0^\circ$					
序号 No.	变更内容 MODIFY CONTENT	日期 MODIFY DATE						

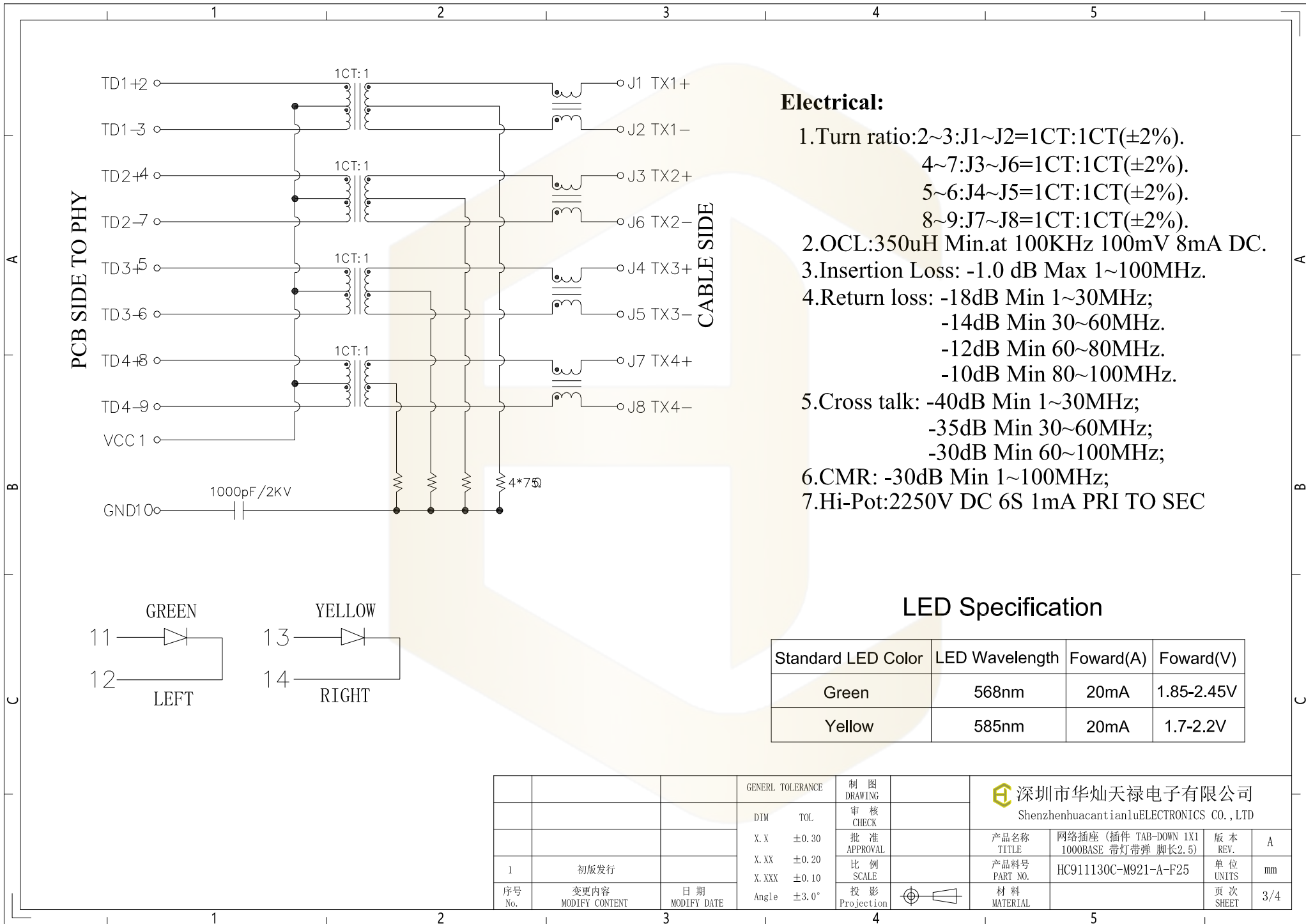

Electrical:

- Turn ratio: 2~3: J1~J2=1CT:1CT(±2%).
4~7: J3~J6=1CT:1CT(±2%).
5~6: J4~J5=1CT:1CT(±2%).
8~9: J7~J8=1CT:1CT(±2%).
- OCL: 350uH Min. at 100KHz 100mV 8mA DC.
- Insertion Loss: -1.0 dB Max 1~100MHz.
- Return loss: -18dB Min 1~30MHz;
-14dB Min 30~60MHz.
-12dB Min 60~80MHz.
-10dB Min 80~100MHz.
- Cross talk: -40dB Min 1~30MHz;
-35dB Min 30~60MHz;
-30dB Min 60~100MHz;
- CMR: -30dB Min 1~100MHz;
- Hi-Pot: 2250V DC 6S 1mA PRI TO SEC

LED Specification

Standard LED Color	LED Wavelength	Foward(A)	Foward(V)
Green	568nm	20mA	1.85-2.45V
Yellow	585nm	20mA	1.7-2.2V

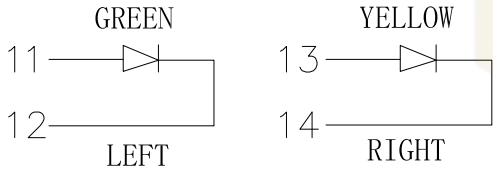

			GENREL TOLERANCE	制图 DRAWING	深圳市华灿天禄电子有限公司 ShenzhenhuacantianluELECTRONICS CO.,LTD			
			DIM TOL	审核 CHECK	产品名称 TITLE	网络插座 (插件 TAB-DOWN 1X1 1000BASE 带灯带弹 脚长2.5)	版本 REV.	A
			X.X ±0.30	批准 APPROVAL	产品料号 PART NO.	HC911130C-M921-A-F25	单位 UNITS	mm
1	初版发行		X.XX ±0.20	比例 SCALE	材料 MATERIAL		页次 SHEET	3/4
序号 No.	变更内容 MODIFY CONTENT	日期 MODIFY DATE	X.XXX ±0.10	投影 Projection				
			Angle ±3.0°					

PROFILE OF WAVE SOLDER

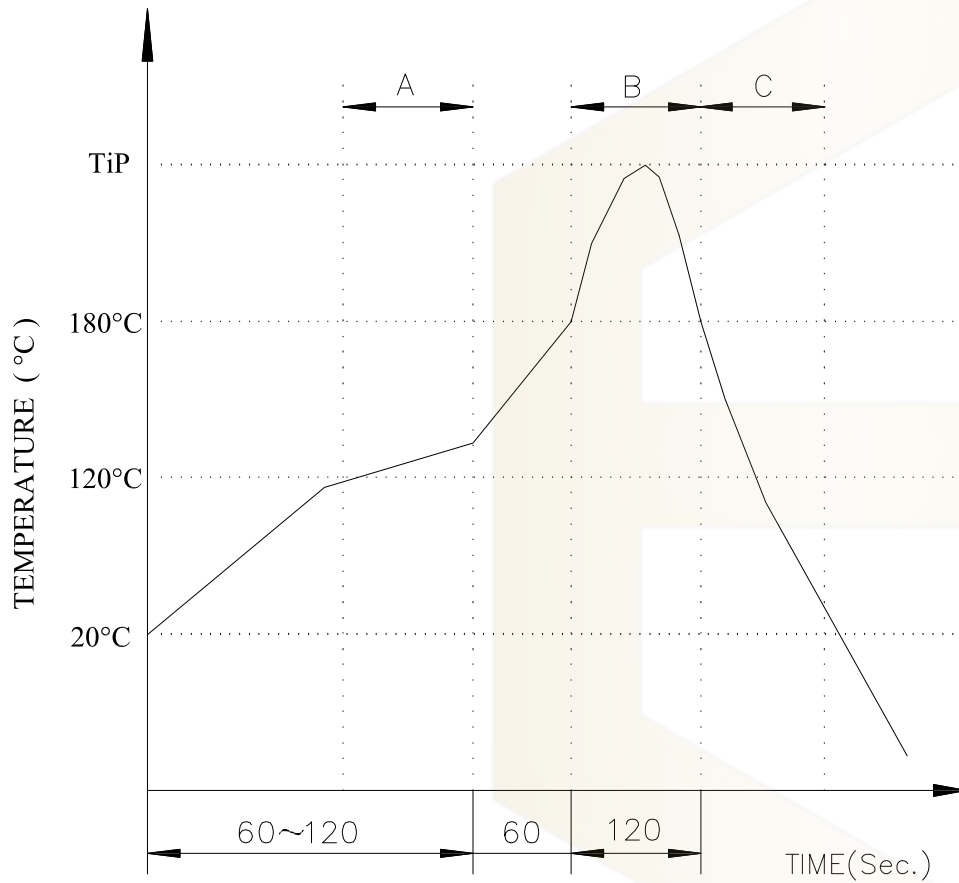

A.Preheating B.Soldering C.Gradual Cooling
 Tip temperature:260°C.
 Tip temperature time:5Sec Max.
 Tip melting point of Sn96.5/Ag3/Cu0.5:217°C.

Remarks: after wave soldering, the plastic positioning columns of the product which under the PCB will be slightly melted, but it won't affect its function.

			GENEAL TOLERANCE	制图 DRAWING	 深圳市华灿天禄电子有限公司 ShenzhenhuacantianluELECTRONICS CO.,LTD			
			DIM TOL	审核 CHECK				
			X.X ±0.30	批准 APPROVAL	产品名称 TITLE	网络插座 (插件 TAB-DOWN 1X1 1000BASE 带灯带弹 脚长2.5)	版本 REV.	A
1	初版发行		X.XX ±0.20	比例 SCALE	产品料号 PART NO.	HC911130C-M921-A-F25	单位 UNITS	mm
序号 No.	变更内容 MODIFY CONTENT	日期 MODIFY DATE	Angle ±3.0°	投影 Projection	材料 MATERIAL		页次 SHEET	4/4