

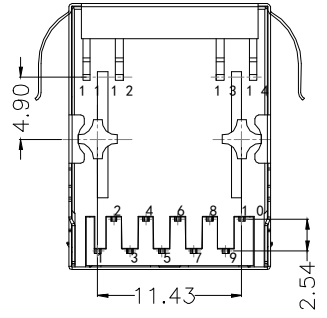

**MATERIAL:**  
 HOUSING : PBT,UL94V-0,BLACK.  
 TERMINALS BRACKET: PBT,UL94V-0,BLACK.  
 SHIELD: C2680,T=0.20MM,NICKEL PLATING ON ALL AREA.  
 TERMINAL: PHOSPHOR BRONZE C5210,T=0.35MM,  
 6U" GOLD PLATING ON CONTACT AREA.

**MECHANICAL:**  
 DURABILITY : 750 CYCLES MIN.  
 MATING FORCE : 23N MAX.  
 OPERATING TEMPERATURE: -40°C~+85°C.  
 STORAGE TEMPERATURE: -40°C~+85°C.  
 ALL CRITICAL DIMENSIONS WITH "\*"

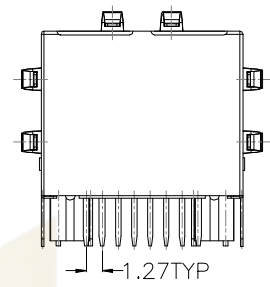
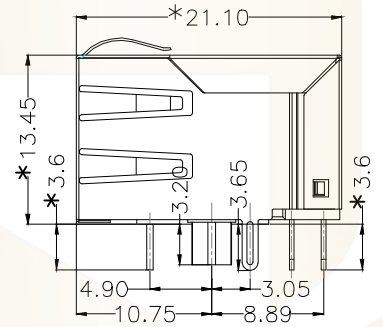
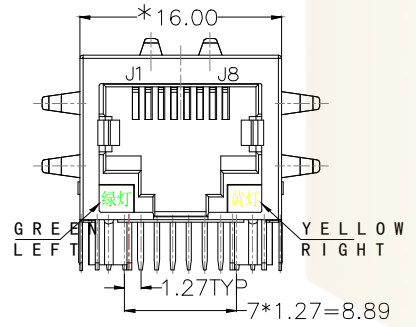
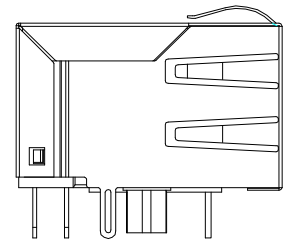
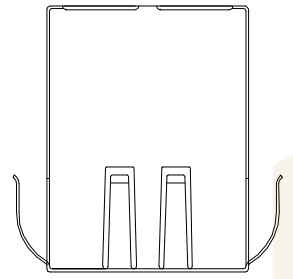

			GENERAL TOLERANCE		制图 DRAWING		 <b>深圳市华灿天禄电子有限公司</b> ShenzhenhuacantianluELECTRONICS CO.,LTD			
			DIM	TOL	审核 CHECK					
			X.X	±0.30	批准 APPROVAL		产品名称 TITLE	网络插座 (插件) 1X1 10/100/1000BASE	版本 REV.	A
1			初版发行		比例 SCALE		产品料号 PART NO.	HC911130C-M892-A	单位 UNITS	mm
序号 No.	变更内容 MODIFY CONTENT	日期 MODIFY DATE	Angle	±3.0°	投影 Projection		材料 MATERIAL		页次 SHEET	1/4

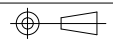
RECOMMENDED PANEL CUTOUT(REFERENCE ONLY):

KEEP-OUT AREA(COMPONENT SIDE VIEW):

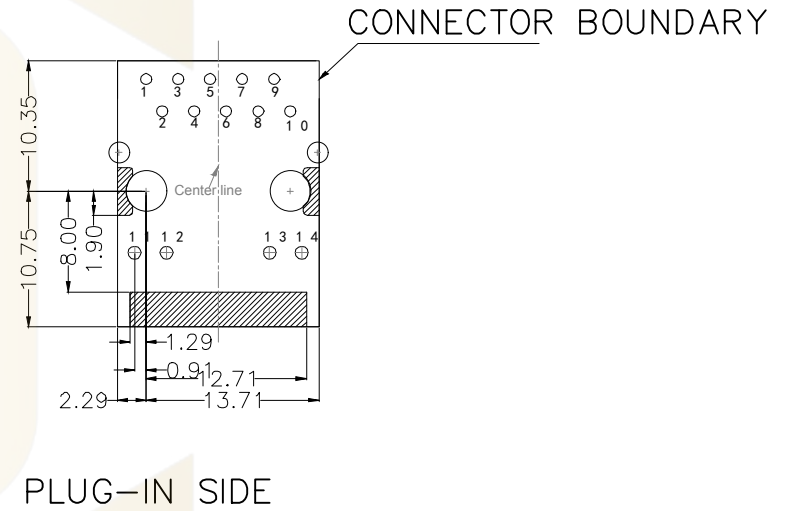
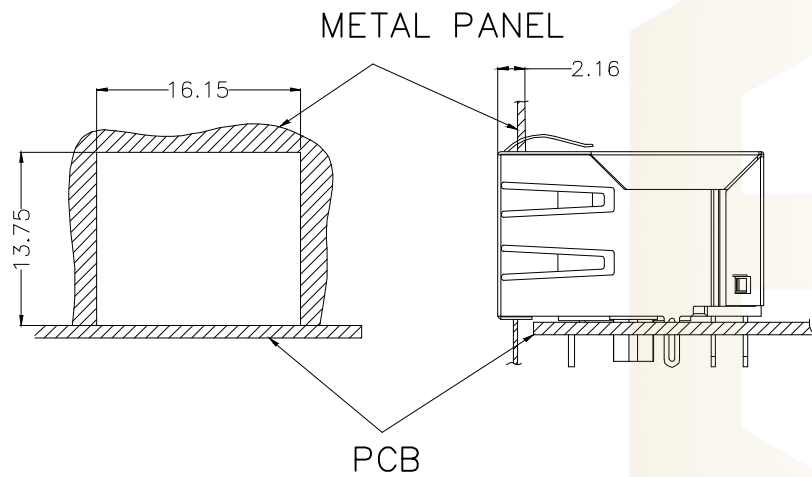

UNIT: MM / INCH  
TOLERANCES:  $\pm 0.10$  / 0.004  
REFERENCE ONLY

UNIT: MM / INCH  
TOLERANCES:  $\pm 0.10$  / 0.004

			GENERAL TOLERANCE		制图 DRAWING		深圳市华灿天禄电子有限公司 ShenzhenhuacantianluELECTRONICS CO., LTD				
			DIM	TOL	审核 CHECK		产品名称 TITLE		网络插座 (插件) 1X1 10/100/1000BASE	版本 REV.	A
			X.X	$\pm 0.30$	批准 APPROVAL		产品料号 PART NO.		HC911130C-M892-A	单位 UNITS	mm
1			初版发行				比例 SCALE			页次 SHEET	2/4
序号 No.	变更内容 MODIFY CONTENT	日期 MODIFY DATE	Angle	$\pm 3.0^\circ$	投影 Projection		材料 MATERIAL				

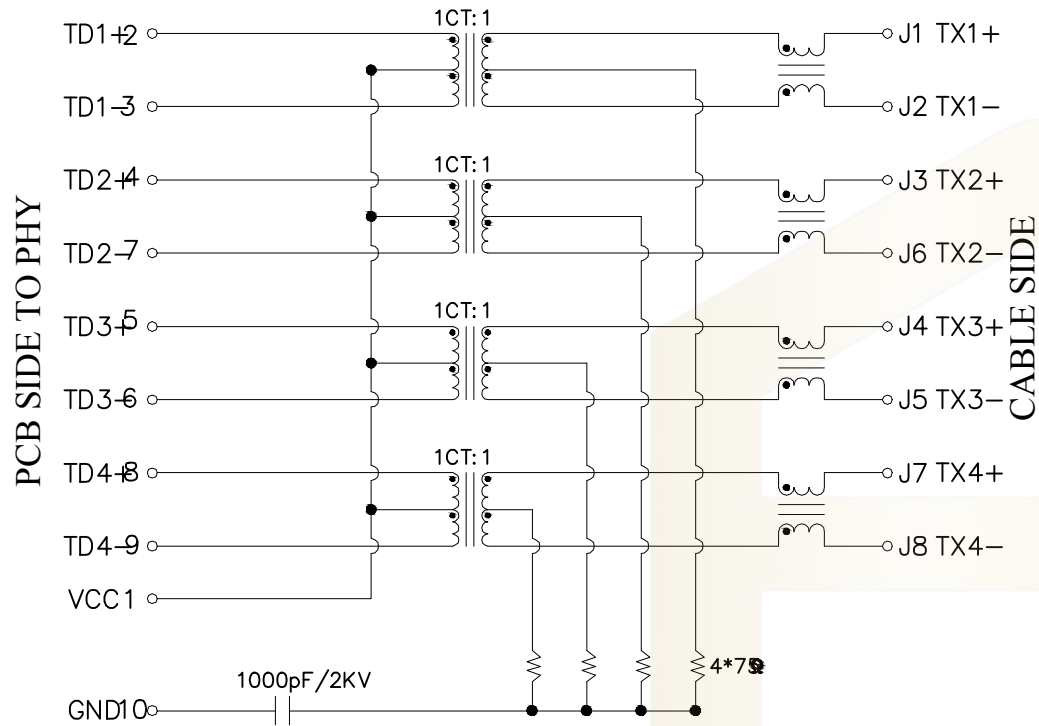

**Electrical:**

1. Turn ratio: 2~3: J1~J2=1CT:1CT(±2%).  
4~7: J3~J6=1CT:1CT(±2%).  
5~6: J4~J5=1CT:1CT(±2%).  
8~9: J7~J8=1CT:1CT(±2%).
2. OCL: 350uH Min. at 100KHz 100mV 8mA DC.
3. Insertion Loss: -1.0 dB Max 1~100MHz.
4. Return loss: -18dB Min 1~30MHz;  
-14dB Min 30~60MHz.  
-12dB Min 60~80MHz.  
-10dB Min 80~100MHz.
5. Cross talk: -40dB Min 1~30MHz;  
-35dB Min 30~60MHz;  
-30dB Min 60~100MHz;
6. CMR: -30dB Min 1~100MHz;
7. Hi-Pot: 2250V DC 6S 1mA PRI TO SEC

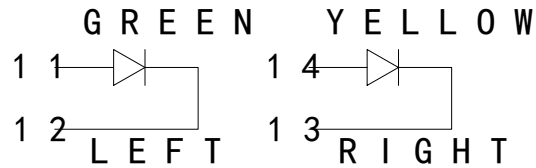

**LED Specification**

Standard LED Color	LED Wavelength	Foward(A)	Foward(V)
Green	568nm	20mA	1.85-2.45V
Yellow	585nm	20mA	1.7-2.2V

		GENERAL TOLERANCE		制 图 DRAWING		 <b>深圳市华灿天禄电子有限公司</b> ShenzhenhuacantianluELECTRONICS CO., LTD					
		DIM TOL		审 核 CHECK							
		X. X ±0.30		批 准 APPROVAL		产品名称 TITLE		网络插座 (插件 1X1 10/100/1000BASE)		版本 REV.	A
1		初版发行		X. XX ±0.20		产品料号 PART NO.		HC911130C-M892-A		单 位 UNITS	mm
序号 No.	变更内容 MODIFY CONTENT	日期 MODIFY DATE		X. XXX ±0.10		投 影 Projection		材 料 MATERIAL		页 次 SHEET	3/4
		Angle ±3.0°									

# PROFILE OF WAVE SOLDER

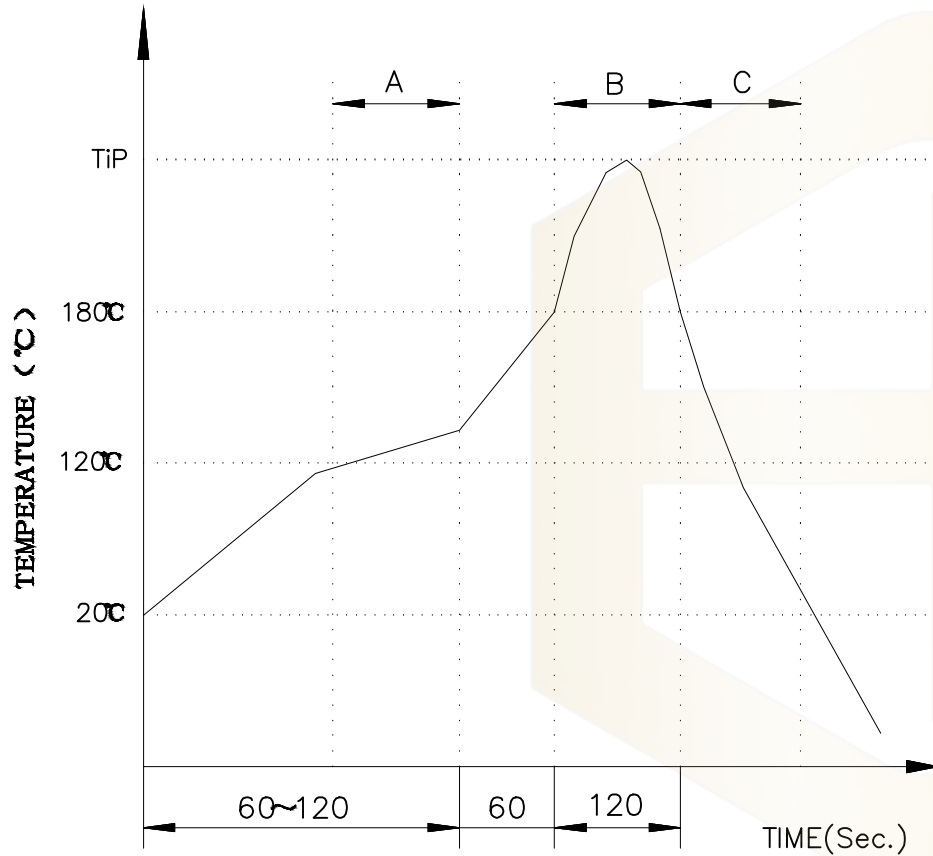

A.Preheating B.Soldering C.Gradual Cooling  
 Tip temperature:260±5°C.  
 Tip temperature time:5Sec Max.  
 Tip melting point of Sn96.5/Ag3/Cu0.5:217°C.

Remarks: after wave soldering, the plastic positioning columns of the product which under the PCB will be slightly melted, but it won't affect its function.

			GENERAL TOLERANCE		制图 DRAWING	深圳市华灿天禄电子有限公司 ShenzhenhuacantianluELECTRONICS CO., LTD				
			DIM	TOL	审核 CHECK	产品名称 TITLE		网络插座 (插件 1X1 10/100/1000BASE)	版本 REV.	A
			X.X	±0.30	批准 APPROVAL	产品料号 PART NO.		HC911130C-M892-A	单位 UNITS	mm
1	初版发行		X.XX	±0.20	比例 SCALE					
序号 No.	变更内容 MODIFY CONTENT	日期 MODIFY DATE	X.XXX	±0.10	投影 Projection	材料 MATERIAL			页次 SHEET	4/4
			Angle	±3.0°						