

MATERIAL:
 HOUSING: LCP,UL94V-0,BLACK.
 TERMINALS BRACKET: PA46,UL94V-0,BLACK.
 SHIELD: C2680,T=0.20MM,NICKEL PLATING ON ALL AREA.
 TERMINAL: PHOSPHOR BRONZE C5210,T=0.35MM,
 6U" GOLD PLATING ON CONTACT AREA.

MECHANICAL:
 DURABILITY: 750 CYCLES MIN.
 MATING FORCE: 23N MAX.
 OPERATING TEMPERATURE: -40°C~+85°C.
 STORAGE TEMPERATURE: -40°C~+85°C.
 ALL CRITICAL DIMENSIONS WITH "*"

			GENERAL TOLERANCE	制图 DRAWING	 深圳市华灿天禄电子有限公司 ShenzhenhuacantianluELECTRONICS CO.,LTD				
			DIM TOL	审核 CHECK					
			X.X ±0.30	批准 APPROVAL		产品名称 TITLE	网络插座 (插件 左橙右绿 无弹 180° TAB-UP 1X1 1000BASE)	版本 REV.	A
1	初版发行		X.XX ±0.20	比例 SCALE		产品料号 PART NO.	HC915320A-M933-A	单位 UNITS	mm
序号 No.	变更内容 MODIFY CONTENT	日期 MODIFY DATE	Angle ±3.0°	投影 Projection		材料 MATERIAL		页次 SHEET	1/4

Suggested Panel Opening:

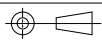
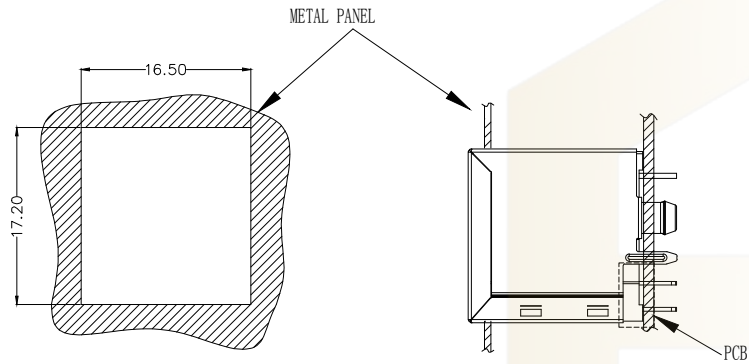

UNIT: mm / inch
Tolerances: $\pm 0.10 / 0.004$

Keep-Out Area (Component Side View):

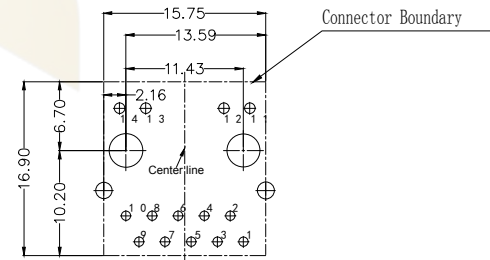

UNIT: mm / inch
Tolerances: $\pm 0.10 / 0.004$

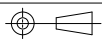
			GENERAL TOLERANCE	制图 DRAWING	 深圳市华灿天禄电子有限公司 ShenzhenhuaciantianluELECTRONICS CO.,LTD					
			DIM TOL	审核 CHECK			产品名称 TITLE	网络插座 (插件 左橙右绿 无弹 180° TAB-UP 1X1 1000BASE)	版本 REV.	A
			X.X ± 0.30	批准 APPROVAL			产品料号 PART NO.	HC915320A-M933-A	单位 UNITS	mm
			X.XX ± 0.20	比例 SCALE			材料 MATERIAL		页次 SHEET	2/4
			X.XXX ± 0.10	投影 Projection						
序号 No.	变更内容 MODIFY CONTENT	日期 MODIFY DATE	Angle $\pm 3.0^\circ$							

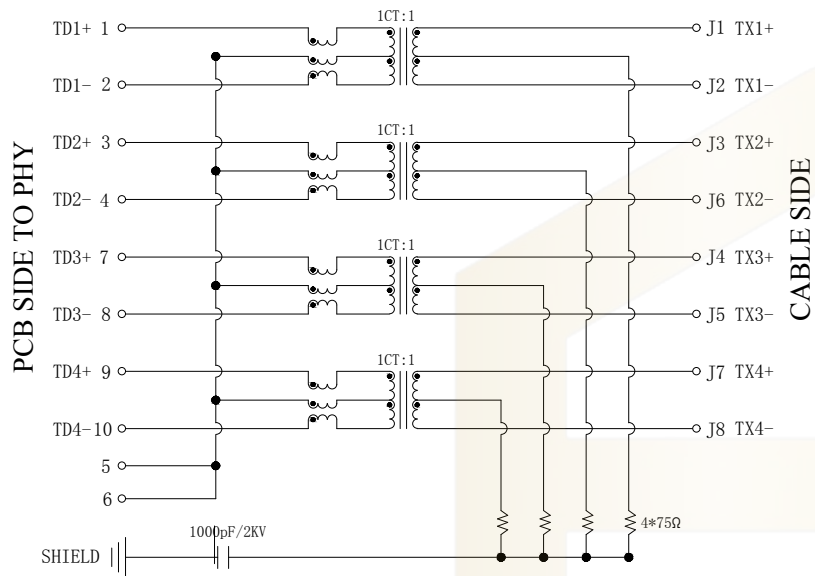

Electrical:

1. Turn ratio: 1~2: J1~J2=1CT:1CT(±2%).
3~4: J3~J6=1CT:1CT(±2%).
7~8: J4~J5=1CT:1CT(±2%).
9~10: J7~J8=1CT:1CT(±2%).
2. OCL: 350uH Min. at 100KHz 100mV 8mA DC.
3. Insertion Loss: -1.0 dB Max 1~100MHz.
4. Return loss: -18dB Min 1~30MHz;
-14dB Min 30~60MHz;
-12dB Min 60~80MHz;
-10dB Min 80~100MHz.
5. Cross talk: -40dB Min 1~30MHz;
-35dB Min 30~60MHz;
-30dB Min 60~100MHz;
6. CMR: -30dB Min 1~100MHz;
7. Hi-Pot: 2250V DC 6S 1mA PRI TO SEC

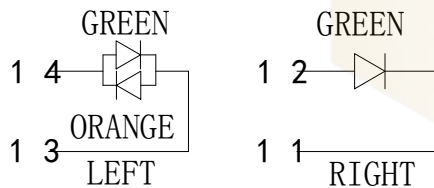

LED Specification

Standard LED Color	LED Wavelength	Foward(A)	Foward(V)
Green	568nm	20mA	1.85-2.45V
Orange	605nm	20mA	1.7-2.2V

			GENEAL TOLERANCE	制图 DRAWING	深圳市华灿天禄电子有限公司 ShenzhenhuacantianluELECTRONICS CO., LTD			
			DIM TOL	审核 CHECK	产品名称 TITLE	网络插座 (插件 左橙右绿 无弹 180° TAB-UP 1X1 1000BASE)	版本 REV.	A
			X.X ±0.30	批准 APPROVAL	产品料号 PART NO.	HC915320A-M933-A	单位 UNITS	mm
1	初版发行		X.XX ±0.20	比例 SCALE	材料 MATERIAL		页次 SHEET	3/4
序号 No.	变更内容 MODIFY CONTENT	日期 MODIFY DATE	X.XXX ±0.10	投影 Projection				
			Angle ±3.0°					

PROFILE OF WAVE SOLDER

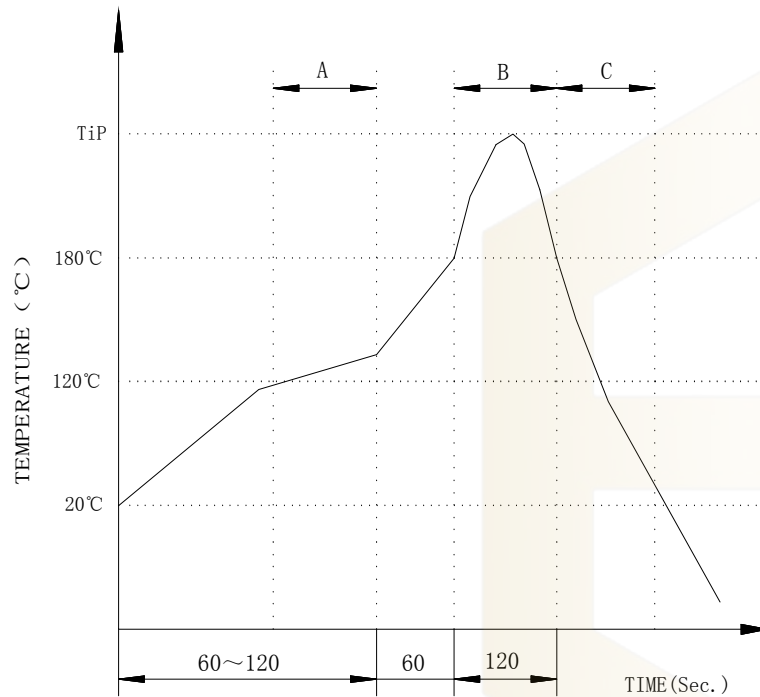

A. Preheating B. Soldering C. Gradual Cooling
 Tip temperature: $260 \pm 5^\circ \text{C}$.
 Tip temperature time: 5Sec Max.
 Tip melting point of Sn96.5/Ag3/Cu0.5: 217°C .

Remarks: after wave soldering, the plastic positioning columns of the product which under the PCB will be slightly melted, but it won't affect its function.

			GENERAL TOLERANCE	制图 DRAWING	 深圳市华灿天禄电子有限公司 ShenzhenhuaciantianluELECTRONICS CO.,LTD			
			DIM TOL	审核 CHECK				
			X.X ±0.30	批准 APPROVAL	产品名称 TITLE	网络插座 (插件 左橙右绿 无弹 180° TAB-UP 1X1 1000BASE)	版本 REV.	A
1	初版发行		X.XX ±0.20	比例 SCALE	产品料号 PART NO.	HC915320A-M933-A	单位 UNITS	mm
序号 No.	变更内容 MODIFY CONTENT	日期 MODIFY DATE	Angle ±3.0°	投影 Projection	材料 MATERIAL		页次 SHEET	4/4