



**MATERIAL:**  
 HOUSING : PBT,UL94V-0,BLACK.  
 TERMINALS BRACKET: PBT,UL94V-0,BLACK.  
 SHIELD: C2680,T=0.20MM,NICKEL PLATING ON ALL AREA.  
 TERMINAL: PHOSPHOR BRONZE C5210,T=0.35MM,  
 6U" GOLD PLATING ON CONTACT AREA.

**MECHANICAL:**  
 DURABILITY : 750 CYCLES MIN.  
 MATING FORCE : 23N MAX.  
 OPERATING TEMPERATURE: -40°C~+85°C.  
 STORAGE TEMPERATURE: -40°C~+85°C.  
 ALL CRITICAL DIMENSIONS WITH "\*"

			GENREL TOLERANCE		制 图 DRAWING		 <b>深圳市华灿天禄电子有限公司</b> ShenzhenhuacantianluELECTRONICS CO.,LTD					
			DIM	TOL	审 核 CHECK		产品名称 TITLE		网络插座 (插件 TAB-UP 1x1 1000BASE 带灯无弹)		版本 REV.	A
			X.X	±0.30	批 准 APPROVAL		产品料号 PART NO.		HC871181AE-M920-A		单 位 UNITS	mm
1			初版发行		投 影 Projection		材 料 MATERIAL				页 次 SHEET	1/4
序号 No.	变更内容 MODIFY CONTENT	日期 MODIFY DATE	Angle ±3.0°									

RECOMMENDED PANEL CUTOUT (REFERENCE ONLY):

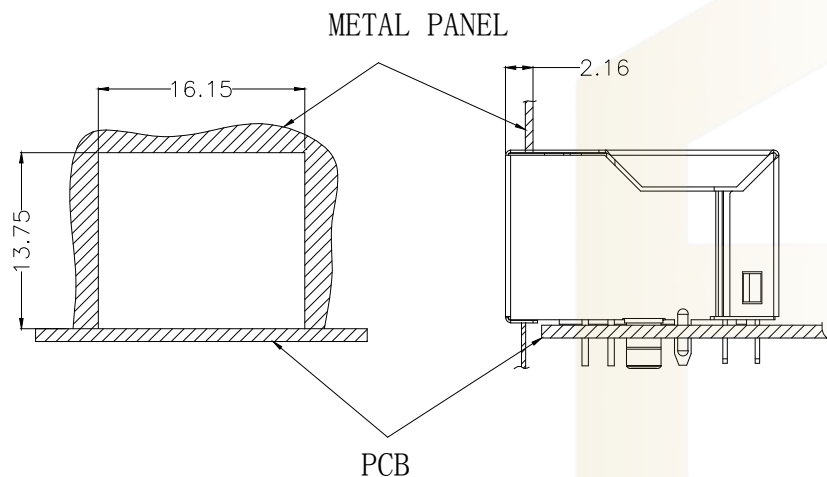

UNIT: MM / INCH  
 TOLERANCES:  $\pm 0.10$  / 0.004  
 REFERENCE ONLY

KEEP-OUT AREA (COMPONENT SIDE VIEW):

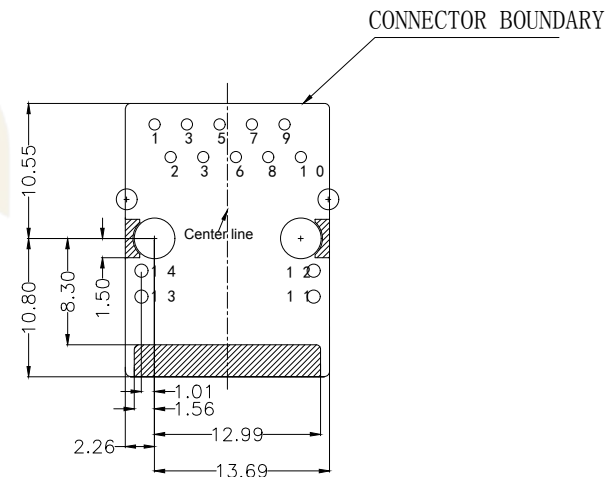

PLUG-IN SIDE

UNIT: MM / INCH  
 TOLERANCES:  $\pm 0.10$  / 0.004

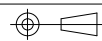
			GENERAL TOLERANCE		制 图 DRAWING		 深圳市华灿天禄电子有限公司 ShenzhenhuacantianluELECTRONICS CO.,LTD					
			DIM	TOL	审 核 CHECK		产品名称 TITLE		网络插座 (插件 TAB-UP 1x1 1000BASE 带灯无弹)	版本 REV.	A	
			X.X	$\pm 0.30$	批 准 APPROVAL		产品料号 PART NO.		HC871181AE-M920-A	单 位 UNITS	mm	
1			初版发行		X.XX		比 例 SCALE					
序号 No.			变更内容 MODIFY CONTENT		日 期 MODIFY DATE		投 影 Projection		材 料 MATERIAL		页 次 SHEET	2/4
			Angle		$\pm 3.0^\circ$							

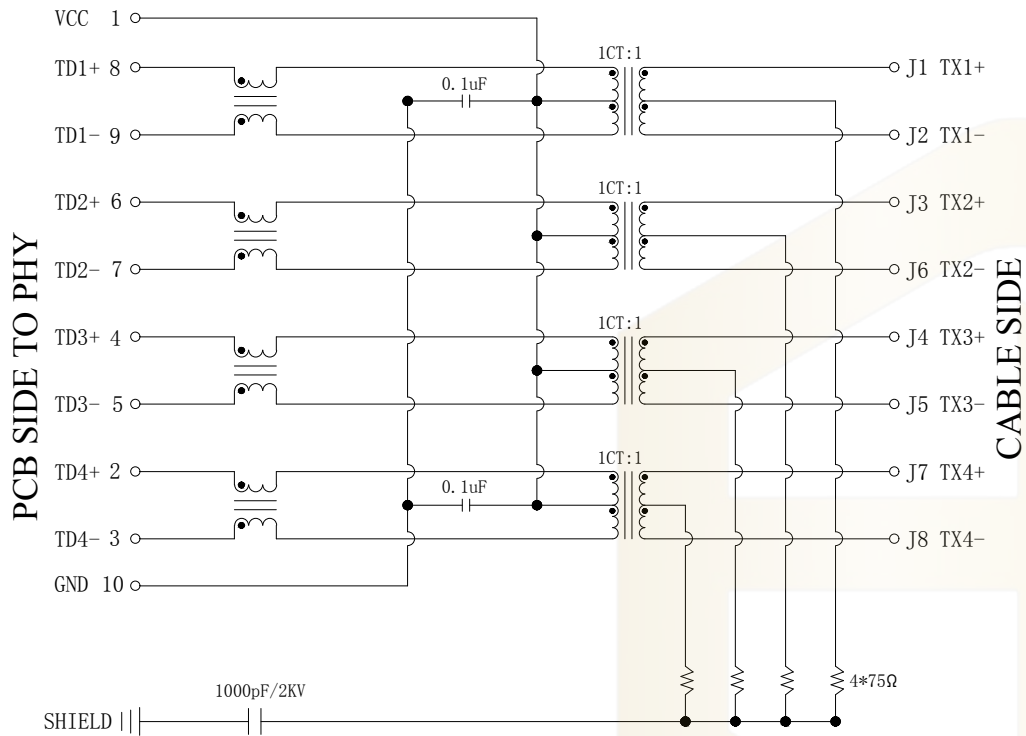

### Electrical:

- Turn ratio: 8~9: J1~J2=1CT:1CT(±2%).  
6~7: J3~J6=1CT:1CT(±2%).  
4~5: J4~J5=1CT:1CT(±2%).  
2~3: J7~J8=1CT:1CT(±2%).
- OCL: 350uH Min. at 100KHz 100mV 8mA DC.
- Insertion Loss: -1.0 dB Max 1~100MHz.
- Return loss: -18dB Min 1~30MHz;  
-14dB Min 30~60MHz.  
-12dB Min 60~80MHz.  
-10dB Min 80~100MHz.
- Cross talk: -40dB Min 1~30MHz;  
-35dB Min 30~60MHz;  
-30dB Min 60~100MHz;
- CMR: -30dB Min 1~100MHz;
- Hi-Pot: 2250V DC 6S 1mA PRI TO SEC

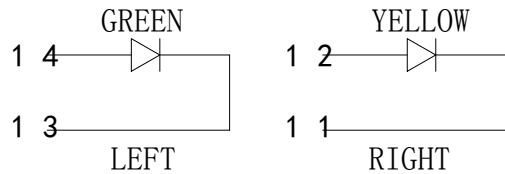

### LED Specification

Standard LED Color	LED Wavelength	Foward(A)	Foward(V)
Green	568nm	20mA	1.85-2.45V
Yellow	585nm	20mA	1.7-2.2V

			GENREL TOLERANCE		制 图 DRAWING		深圳市华灿天禄电子有限公司 ShenzhenhuacantianluELECTRONICS CO., LTD					
			DIM	TOL	审 核 CHECK		产 品 名 称 TITLE		网 络 插 座 (插 件 TAB-UP 1x1 1000BASE 带灯无弹)		版 本 REV.	A
			X. X	±0.30	批 准 APPROVAL		产 品 料 号 PART NO.		HC871181AE-M920-A		单 位 UNITS	mm
1	初版发行		X. XX	±0.20	比 例 SCALE						页 次 SHEET	3/4
序号 No.	变 更 内 容 MODIFY CONTENT	日 期 MODIFY DATE	X. XXX	±0.10	投 影 Projection		材 料 MATERIAL					
			Angle	±3.0°	⊕							

# PROFILE OF WAVE SOLDER

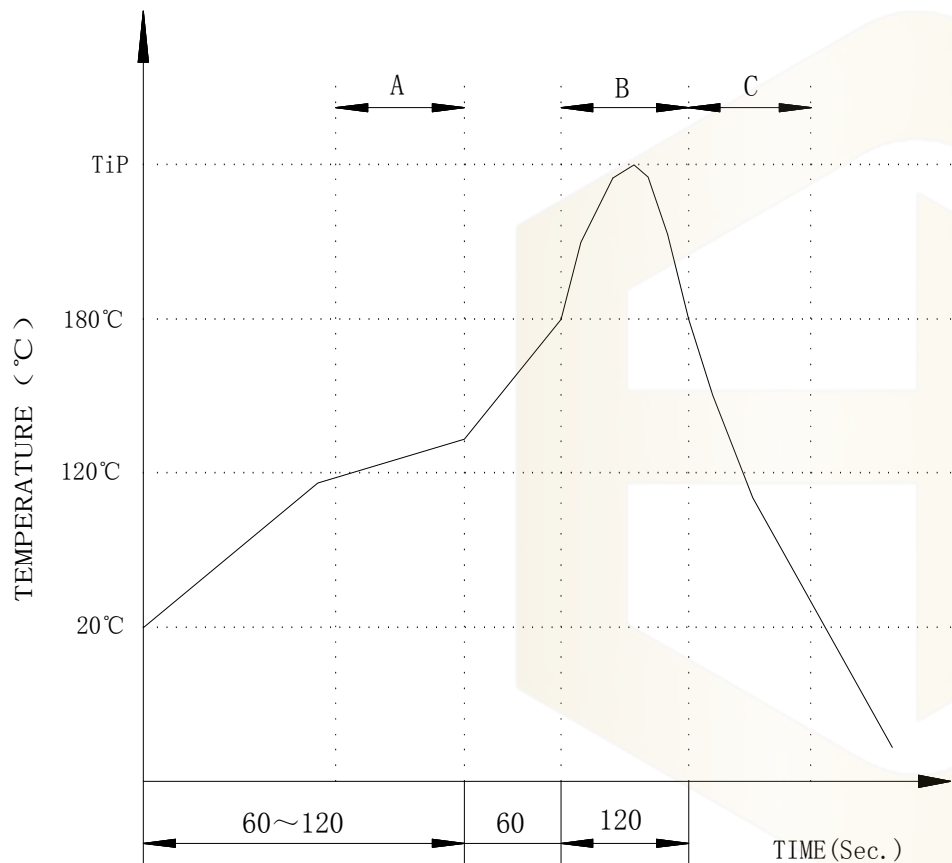

A. Preheating B. Soldering C. Gradual Cooling  
 Tip temperature:  $260 \pm 5^\circ \text{C}$ .  
 Tip temperature time: 5Sec Max.  
 Tip melting point of Sn96.5/Ag3/Cu0.5:  $217^\circ \text{C}$ .

Remarks: after wave soldering, the plastic positioning columns of the product which under the PCB will be slightly melted, but it won't affect its function.

			GENERAL TOLERANCE		制图 DRAWING		 深圳市华灿天禄电子有限公司 ShenzhenhuacantianluELECTRONICS CO., LTD				
			DIM	TOL	审核 CHECK		产品名称 TITLE		网络插座 (插件 TAB-UP 1x1 1000BASE 带灯无弹)	版本 REV.	A
			X. X	$\pm 0.30$	批准 APPROVAL		产品料号 PART NO.		HC871181AE-M920-A	单位 UNITS	mm
1 初版发行			X. XX	$\pm 0.20$	比例 SCALE		材料 MATERIAL			页次 SHEET	4/4
序号 No.	变更内容 MODIFY CONTENT	日期 MODIFY DATE	Angle	$\pm 3.0^\circ$	投影 Projection		