

MATERIAL:

HOUSING : PA9T,UL94V-0,BLACK.
 TERMINALS BRACKET: PA9T,UL94V-0,BLACK.
 SHIELD: BRASS,T=0.20MM,NICKEL PLATING ON ALL AREA.
 TERMINAL: PHOSPHOR BRONZE ,T=0.35MM,
 6U" GOLD PLATING ON CONTACT AREA.

MECHANICAL:

DURABILITY : 750 CYCLES MIN.
 MATING FORCE : 23N MAX.
 OPERATING TEMPERATURE: -40°C~+85°C.
 STORAGE TEMPERATURE: -40°C~+85°C.
 ALL CRITICAL DIMENSIONS WITH "*"*

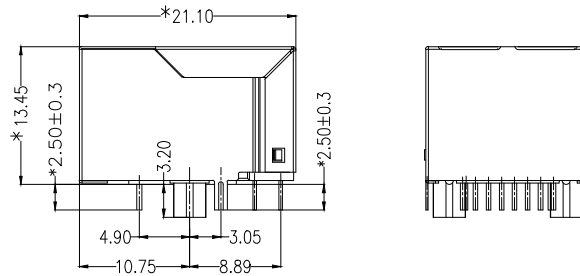
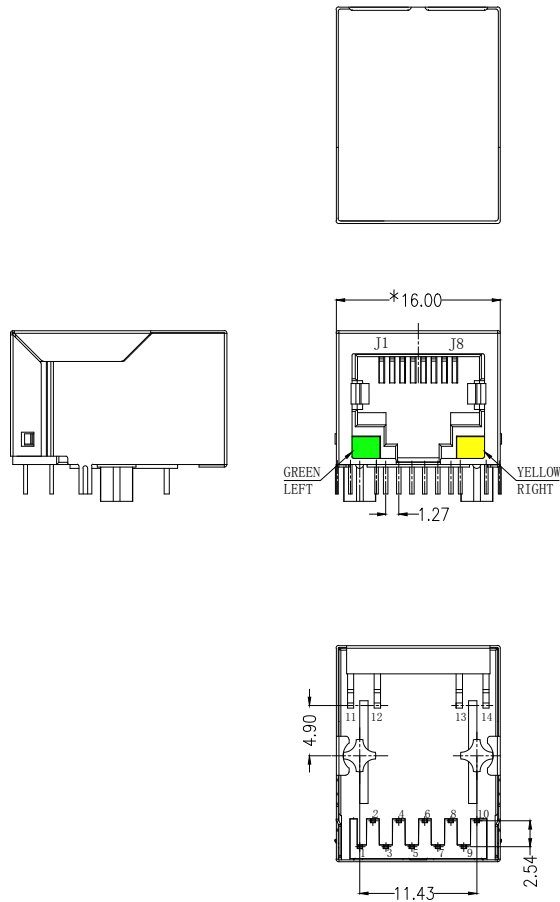

Ordering Information

HC 6* * * ** A - M*** - A

Type	LED Color	EMI	Ports	产品序号
61-卧式插件	0-无灯	0-无弹	1-813	
62-立式插件	1-带灯 (左黄右绿)	1-带弹	01-113	
63-卧式贴片	2-带灯 (左绿右黄)	0-无弹	02-213	
64-立式贴片	3-带灯 (左绿右黄)	0-无弹	Shielding	
	4-带灯 (左绿右黄)	1-带弹	22-02213	
	5-带灯 (左绿右黄, 绿-黄)			
	6-带灯 (左绿, 右黄)			
	7-带灯 (左绿, 右绿)			
	8-带灯 (左绿, 右绿)			

			GENRL TOLERANCE	制图 DRAWING	深圳市华灿天禄电子有限公司 ShenzhenhuacantianluELECTRONICS CO.,LTD			
			DIM TOL	审核 CHECK				
			X.X ±0.30	批准 APPROVAL	产品名称 TITLE	网络插座 (插件 带灯无弹 左绿 右黄 TAB-DOWN 1X1 1000BASE) 过回流焊	版本 REV.	A
1	初版发行		X.XX ±0.20	比例 SCALE	产品料号 PART NO.	HC612601A-M893-A-PA9T	单位 UNITS	mm
序号 No.	变更内容 MODIFY CONTENT	日期 MODIFY DATE	X.XXX ±0.10	投影 Projection	材料 MATERIAL		页次 SHEET	1/4
			Angle ±3.0°					

RECOMMENDED PANEL CUTOUT (REFERENCE ONLY) :

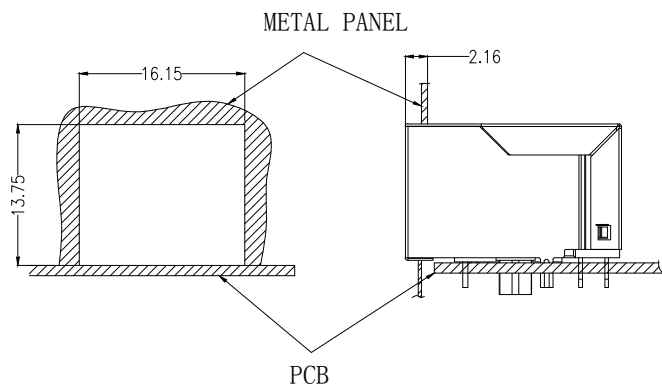

UNIT: MM / INCH
 TOLERANCES: ± 0.10 / 0.004
 REFERENCE ONLY

KEEP-OUT AREA (COMPONENT SIDE VIEW) :

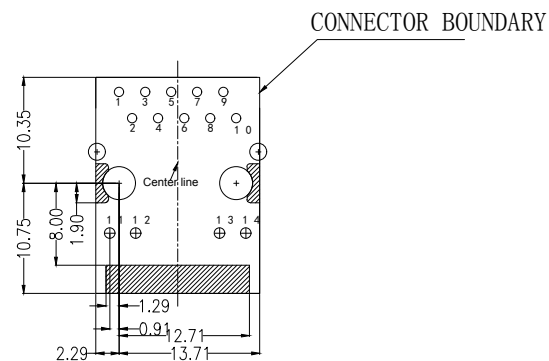

PLUG-IN SIDE

UNIT: MM / INCH
 TOLERANCES: ± 0.10 / 0.004

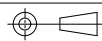
			GENEAL TOLERANCE	制图 DRAWING	 深圳市华灿天禄电子有限公司 ShenzhenhuacantianluELECTRONICS CO.,LTD			
			DIM TOL	审核 CHECK	产品名称 TITLE	网络插座 (插件 带灯无弹 左绿 右黄 TAB-DOWN 1X1 1000BASE) 过回流焊	版本 REV.	A
			X.X ± 0.30	批准 APPROVAL	产品料号 PART NO.	HC612601A-M893-A-PA9T	单位 UNITS	mm
1	初版发行		X.XX ± 0.20	比例 SCALE	材料 MATERIAL		页次 SHEET	2/4
序号 No.	变更内容 MODIFY CONTENT	日期 MODIFY DATE	X.XXX ± 0.10	投影 Projection				
			Angle $\pm 3.0^\circ$					

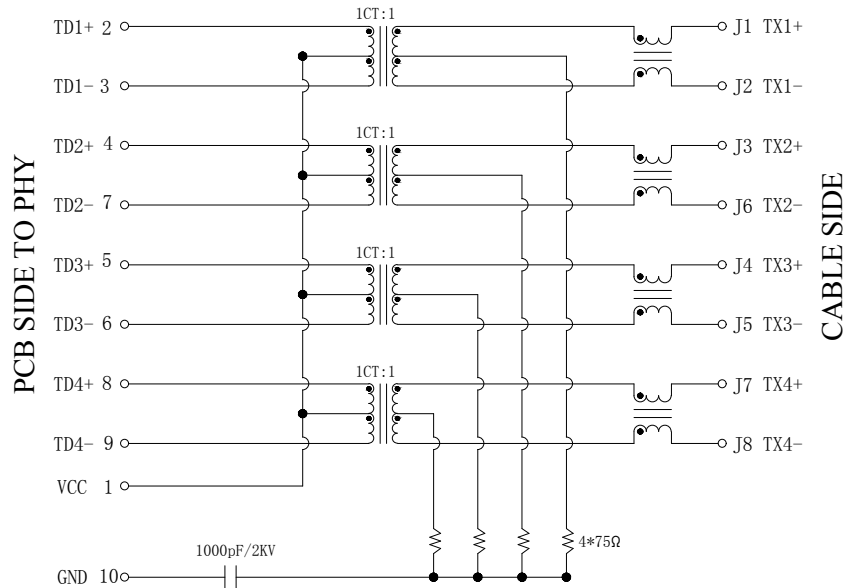

Electrical:

1. Turn ratio: 2~3: J1~J2=1CT:1CT(±2%).
4~7: J3~J6=1CT:1CT(±2%).
5~6: J4~J5=1CT:1CT(±2%).
8~9: J7~J8=1CT:1CT(±2%).
2. OCL: 350uH Min. at 100KHz 100mV 8mA DC.
3. Insertion Loss: -1.0 dB Max 1~100MHz.
4. Return loss: -18dB Min 1~30MHz;
-14dB Min 30~60MHz.
-12dB Min 60~80MHz.
-10dB Min 80~100MHz.
5. Cross talk: -40dB Min 1~30MHz;
-35dB Min 30~60MHz;
-30dB Min 60~100MHz;
6. CMR: -30dB Min 1~100MHz;
7. Hi-Pot: 2250V DC 6S 1mA PRI TO SEC

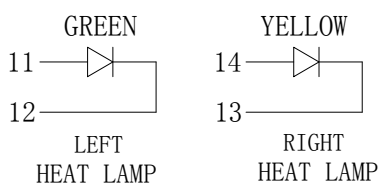

LED Specification

Standard LED Color	LED Wavelength	Foward(A)	Foward(V)
Green	568nm	20mA	1.85-2.45V
Yellow	585nm	20mA	1.7-2.2V

		GENEAL TOLERANCE		制图 DRAWING	深圳市华灿天禄电子有限公司 ShenzhenhuacantianluELECTRONICS CO., LTD				
		DIM	TOL	审核 CHECK	产品名称 TITLE		网络插座 (插件 带灯无弹 左绿 右黄 TAB-DOWN 1X1 1000BASE) 过回流焊	版本 REV.	A
		X. X	±0.30	批准 APPROVAL	产品料号 PART NO.		HC612601A-M893-A-PA9T	单位 UNITS	mm
1	初版发行	X. XX	±0.20	比例 SCALE	材料 MATERIAL			页次 SHEET	3/4
序号 No.	变更内容 MODIFY CONTENT	日期 MODIFY DATE	X. XXX ±0.10	投影 Projection					
			Angle ±3.0°						

PROFILE OF REFLOW SOLDERING

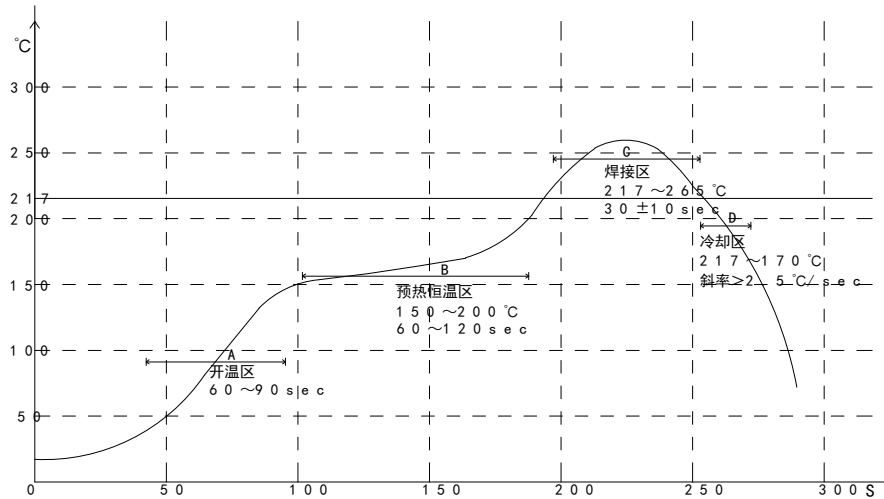

- A. Temperature range of open
- B. Preheat temperature zone
- C. The welding zone
- D. The cooling zone

Tip temperature: $265 \pm 5^\circ \text{C}$.

Tip temperature time: $30 \pm 10 \text{Sec}$.

Tip melting point of Sn96.5/Ag3/Cu0.5.

			GENEAL TOLERANCE	制图 DRAWING	深圳市华灿天禄电子有限公司 ShenzhenhuacantianluELECTRONICS CO., LTD					
			DIM TOL	审核 CHECK			产品名称 TITLE	网络插座 (插件 带灯无弹 左绿 右黄 TAB-DOWN 1X1 1000BASE) 过回流焊	版本 REV.	A
			X.X ±0.30	批准 APPROVAL			产品料号 PART NO.	HC612601A-M893-A-PA9T	单位 UNITS	mm
			X.XX ±0.20	比例 SCALE			材料 MATERIAL		页次 SHEET	4/4
			X.XXX ±0.10	投影 Projection						
1	初版发行		Angle ±3.0°							
序号 No.	变更内容 MODIFY CONTENT	日期 MODIFY DATE								