

MATERIAL:

HOUSING : PBT,UL94V-0,BLACK.
 TERMINALS BRACKET: PBT,UL94V-0,BLACK.
 SHIELD: C2680,T=0.20MM,NICKEL PLATING ON ALL AREA.
 TERMINAL: PHOSPHOR BRONZE C5210,T=0.35MM,
 6U" GOLD PLATING ON CONTACT AREA.

MECHANICAL:

DURABILITY : 750 CYCLES MIN.
 MATING FORCE : 23N MAX.
 OPERATING TEMPERATURE: -40°C~+85°C.
 STORAGE TEMPERATURE: -40°C~+85°C.
 ALL CRITICAL DIMENSIONS WITH "*"

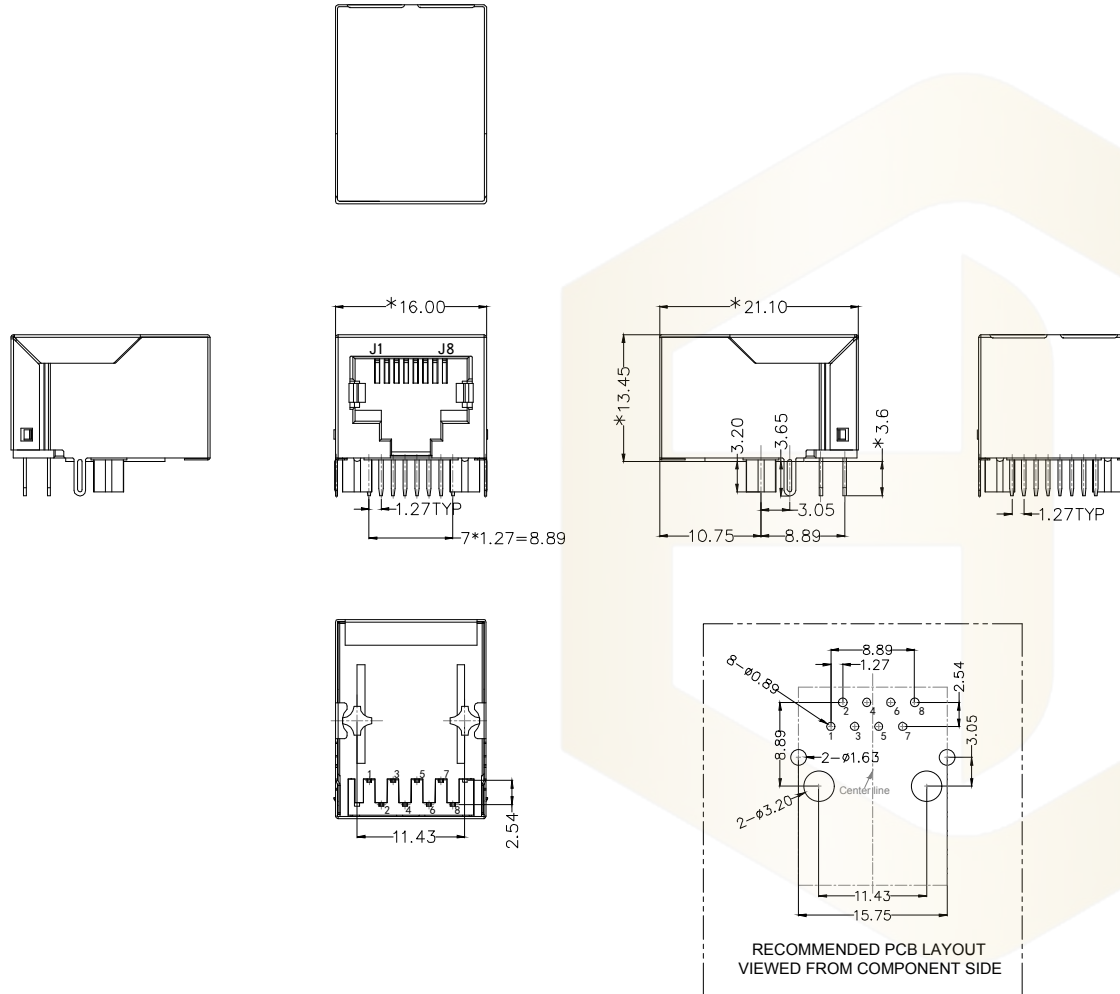

Ordering Information

HC 61 * * 01 A - M941 - A

Type	LED Color	EMI	产品序号
61-卧式插座 62-立式插座 63-卧式贴片 64-立式贴片	0-无灯 1-橙灯 (左黄右绿) 2-橙灯 (左绿右黄) 3-橙灯 (左黄右绿) 4-橙灯 (左绿右黄)	0-无EMI 7-带EMI	

			GENERAL TOLERANCE	制图 DRAWING	深圳市华灿天禄电子有限公司 ShenzhenhuacantianluELECTRONICS CO.,LTD			
			DIM TOL	审核 CHECK	产品名称 TITLE	网络插座 (卧插 无灯无弹 TAB-DOWN 1X1 10/100BASE)	版本 REV.	A
			X.X ±0.30	批准 APPROVAL	产品料号 PART NO.	HC610601A-M941-A	单位 UNITS	mm
			X.XX ±0.20	比例 SCALE	材料 MATERIAL		页次 SHEET	1/4
			X.XXX ±0.10	投影 Projection				
序号 No.	变更内容 MODIFY CONTENT	日期 MODIFY DATE	Angle ±3.0°					

RECOMMENDED PANEL CUTOUT(REFFERENCE ONLY):

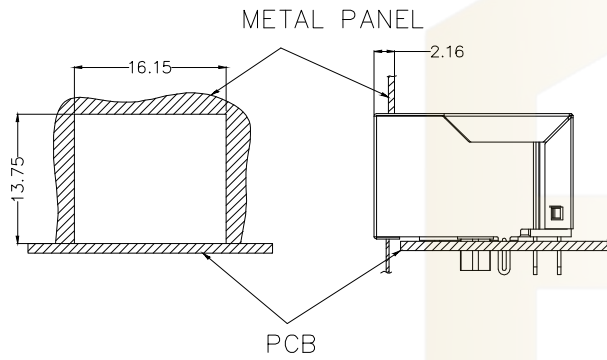

KEEP-OUT AREA(COMPONENT SIDE VIEW):

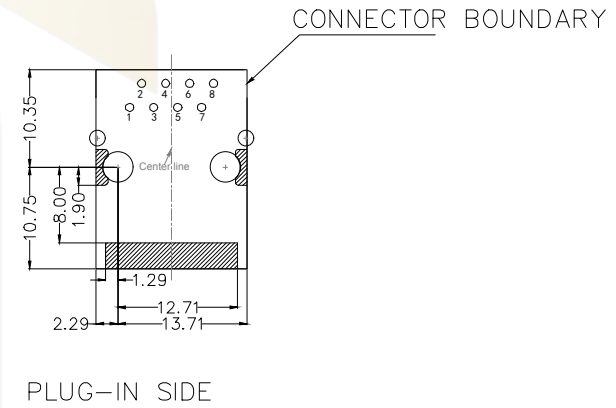

UNIT: MM / INCH
TOLERANCES: ? .10 / 0.004

			GENERAL TOLERANCE	制图 DRAWING	 深圳市华灿天禄电子有限公司 ShenzhenhuaciantianluELECTRONICS CO.,LTD			
			DIM TOL	审核 CHECK	产品名称 TITLE	网络插座 (卧插 无灯无弹) TAB-DOWN 1X1 10/100BASE)	版本 REV.	A
			X.X ±0.30	批准 APPROVAL	产品料号 PART NO.	HC610601A-M941-A	单位 UNITS	mm
			X.XX ±0.20	比例 SCALE	材料 MATERIAL		页次 SHEET	2/4
			X.XXX ±0.10	投影 Projection				
序号 No.	变更内容 MODIFY CONTENT	日期 MODIFY DATE	Angle ±3.0°					

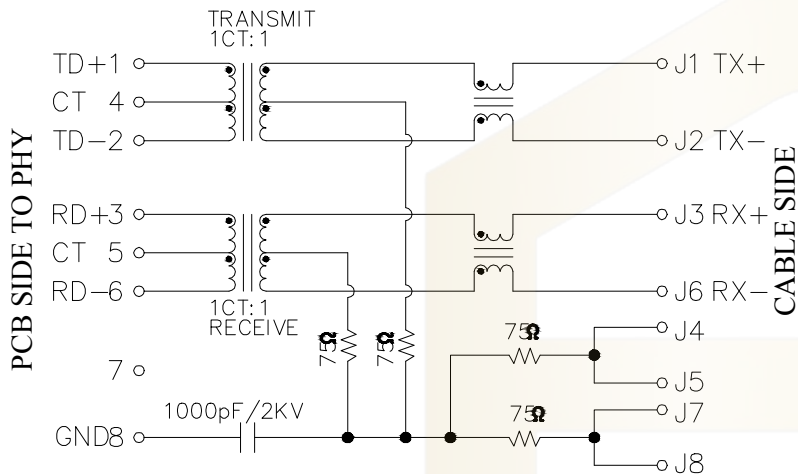

Electrical:

1. Turn ratio: 1~2: J1~J2=1CT:1CT(±2%).
3~6: J3~J6=1CT:1CT(±2%).
2. OCL: 350uH Min. at 100KHz 100mV 8mA DC.
3. Insertion Loss: -1.0 dB Max 1~100MHz.
4. Return loss: -20dB Min 1~10MHz;
-16dB Min 10~30MHz.
-12dB Min 30~60MHz.
-10dB Min 60~80MHz.
5. Cross talk: -40dB Min 1~30MHz;
-35dB Min 30~60MHz;
-30dB Min 60~100MHz;
6. CMR: -30dB Min 1~100MHz;
7. Hi-Pot: 1500V AC & 2250V DC
6S 1mA PRI TO SEC

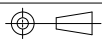
			GENERAL TOLERANCE	制图 DRAWING	 深圳市华灿天禄电子有限公司 ShenzhenhuaciantianluELECTRONICS CO., LTD					
			DIM TOL	审核 CHECK			产品名称 TITLE	网络插座 (卧插 无灯无弹) TAB-DOWN 1X1 10/100BASE)	版本 REV.	A
			X.X ±0.30	批准 APPROVAL			产品料号 PART NO.	HC610601A-M941-A	单位 UNITS	mm
			X.XX ±0.20	投影 Projection			材料 MATERIAL			
			X.XXX ±0.10							
序号 No.	变更内容 MODIFY CONTENT	日期 MODIFY DATE	Angle ±3.0°							

PROFILE OF WAVE SOLDER

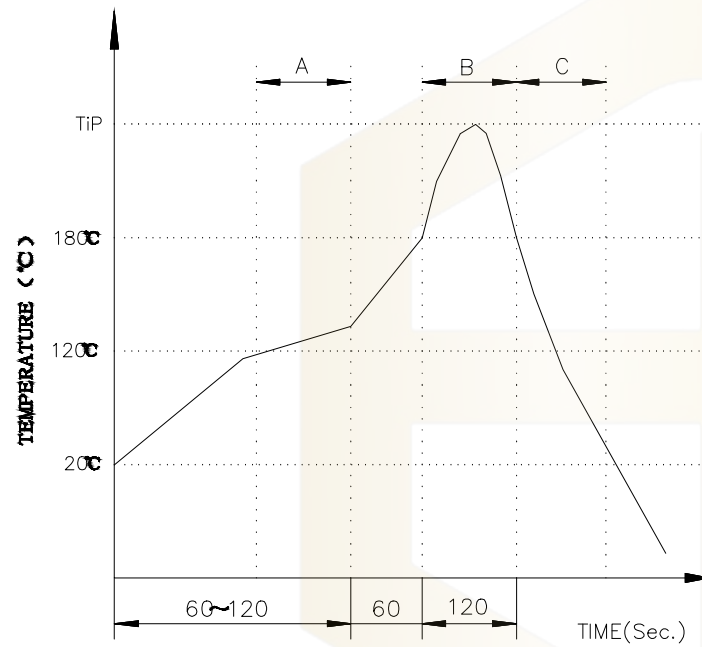

A. Preheating B. Soldering C. Gradual Cooling
 Tip temperature: $260 \pm 5^\circ \text{C}$.
 Tip temperature time: 5Sec Max.
 Tip melting point of Sn96.5/Ag3/Cu0.5: 217°C .

Remarks: after wave soldering, the plastic positioning columns of the product which under the PCB will be slightly melted, but it won't affect its function.

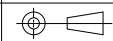
			GENERAL TOLERANCE	制图 DRAWING	 深圳市华灿天禄电子有限公司 ShenzhenhuaciantianluELECTRONICS CO.,LTD					
			DIM TOL	审核 CHECK			产品名称 TITLE	网络插座 (卧插 无灯无弹) TAB-DOWN 1X1 10/100BASE)	版本 REV.	A
			X.X ±0.30	批准 APPROVAL			产品料号 PART NO.	HC610601A-M941-A	单位 UNITS	mm
			X.XX ±0.20	比例 SCALE			材料 MATERIAL		页次 SHEET	4/4
			X.XXX ±0.10	投影 Projection						
序号 No.	变更内容 MODIFY CONTENT	日期 MODIFY DATE	Angle ±3.0°							