

		GENERAL TOLERANCE		制图 DRAWING		深圳市华灿天禄电子有限公司 ShenzhenhuacantianluELECTRONICS CO.,LTD			
		DIM	TOL	审核 CHECK		产品名称 TITLE	网络插座 (卧插 带灯无弹 左绿 右黄 TAB-UP 1x1 100BASE)	版本 REV.	A
		X.X	±0.30	批准 APPROVAL		产品料号 PART NO.	HC612601A-M411-A	单位 UNITS	mm
1	初版发行	X.XX	±0.20	比例 SCALE		材料 MATERIAL		页次 SHEET	1/4
序号 No.	变更内容 MODIFY CONTENT	日期 MODIFY DATE	X.XXX	±0.10	投影 Projection				
			Angle	±3.0°					

RECOMMENDED PANEL CUTOUT (REFERENCE ONLY) :

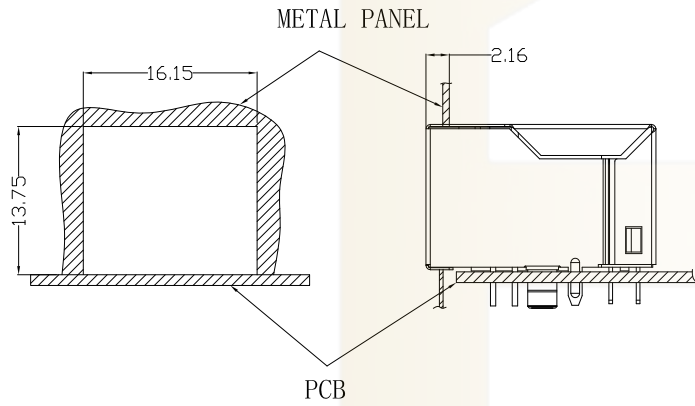

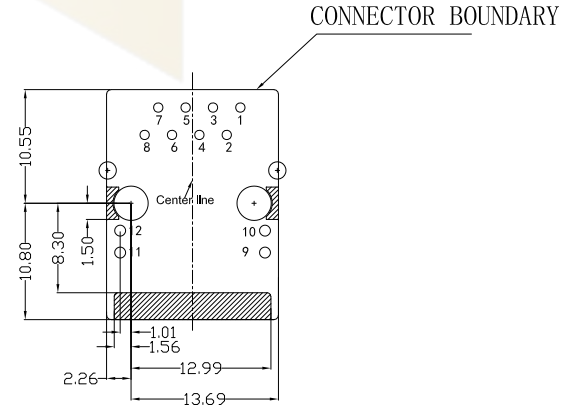

UNIT: MM / INCH
 TOLERANCES: $\pm 0.10 / 0.004$
 REFERENCE ONLY

KEEP-OUT AREA (COMPONENT SIDE VIEW) :



PLUG-IN SIDE

UNIT: MM / INCH
 TOLERANCES: $\pm 0.10 / 0.004$

			GENEAL TOLERANCE	制 图 DRAWING	 深圳市华灿天禄电子有限公司 ShenzhenhuacantianluELECTRONICS CO., LTD				
			DIM TOL	审 核 CHECK		产品名称 TITLE	网络插座 (卧插 带灯无弹 左绿 右黄 TAB-UP 1x1 100BASE)	版 本 REV.	A
			X.X ± 0.30	批 准 APPROVAL		产品料号 PART NO.	HC612601A-M411-A	单 位 UNITS	mm
1	初版发行		X.XX ± 0.20	投 影 SCALE		材 料 MATERIAL		页 次 SHEET	2/4
序号 No.	变更内容 MODIFY CONTENT	日期 MODIFY DATE	X.XXX ± 0.10	Angle $\pm 3.0^\circ$	 Projection				

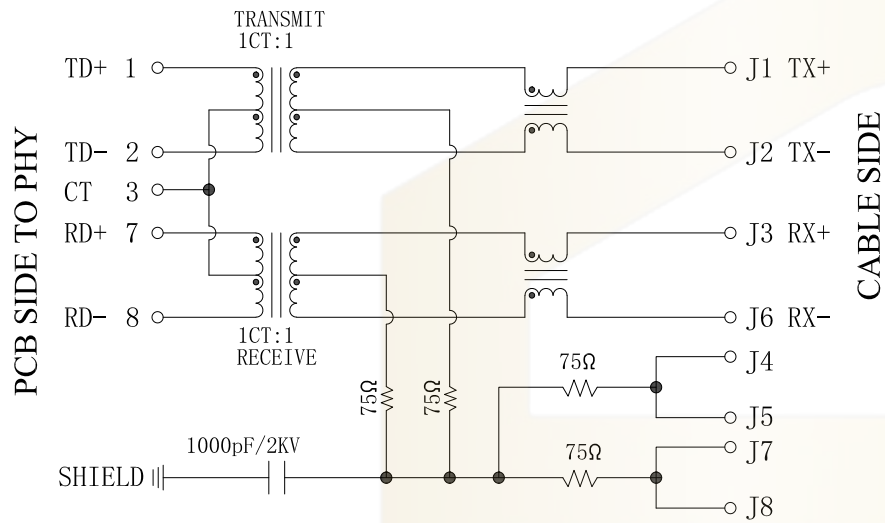

Electrical:

1. Turn ratio: 1~2: J1~J2=1CT:1CT(±2%).
7~8: J3~J6=1CT:1CT(±2%).
2. OCL: 350uH Min. at 100KHz 100mV 8mA DC.
3. Insertion Loss: -1.0 dB Max 1~100MHz.
4. Return loss: -20dB Min 1~10MHz;
-16dB Min 10~30MHz.
-12dB Min 30~60MHz.
-10dB Min 60~80MHz.
5. Cross talk: -40dB Min 1~30MHz;
-35dB Min 30~60MHz;
-30dB Min 60~100MHz;
6. CMR: -30dB Min 1~100MHz;
7. Hi-Pot: 1500V AC & 2250V DC
6S 1mA PRI TO SEC

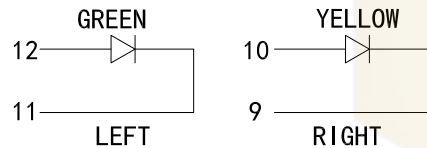

LED Specification

Standard LED Color	LED Wavelength	Foward(A)	Foward(V)
Green	568nm	20mA	1.85-2.45V
Yellow	585nm	20mA	1.7-2.2V

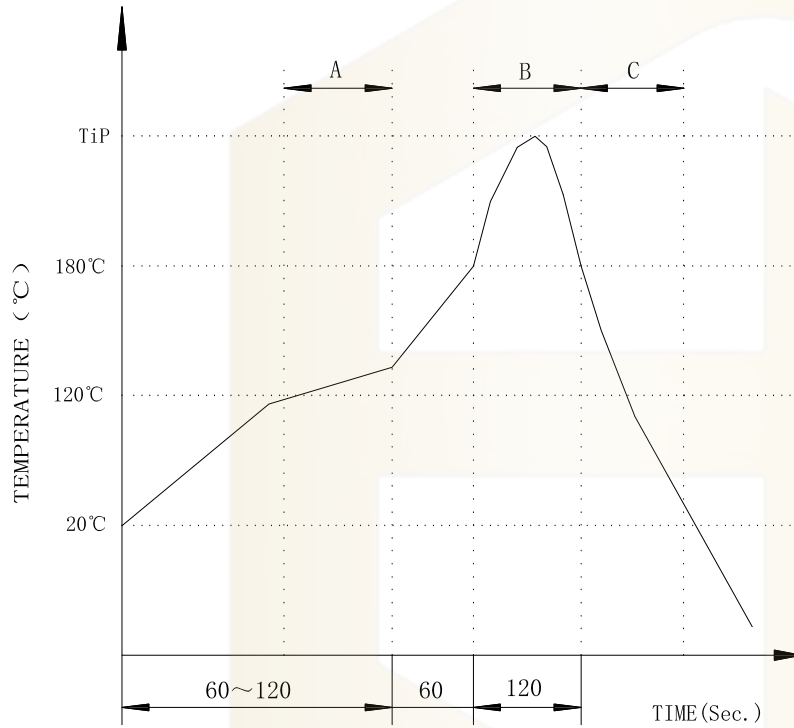

			GENEAL TOLERANCE	制 图 DRAWING	深圳市华灿天禄电子有限公司 ShenzhenhuacantianluELECTRONICS CO., LTD			
			DIM TOL	审 核 CHECK				
			X. X ±0.30	批 准 APPROVAL	产品名称 TITLE	网络插座 (卧插 带灯无弹 左绿 右黄 TAB-UP 1x1 100BASE)	版 本 REV.	A
1	初版发行		X. XX ±0.20	投 影 SCALE	产品料号 PART NO.	HC612601A-M411-A	单 位 UNITS	mm
序号 No.	变更内容 MODIFY CONTENT	日期 MODIFY DATE	X. XXX ±0.10	Angle ±3.0°	材 料 MATERIAL		页 次 SHEET	3/4

PROFILE OF WAVE SOLDER



A.Preheating B.Soldering C.Gradual Cooling
 Tip temperature:260±5°C.
 Tip temperature time:5Sec Max.
 Tip melting point of Sn96.5/Ag3/Cu0.5:217°C.

Remarks: after wave soldering, the plastic positioning columns of the product which under the PCB will be slightly melted, but it won't affect its function.

			GENERAL TOLERANCE	制图 DRAWING	 深圳市华灿天禄电子有限公司 ShenzhenhuacantianluELECTRONICS CO., LTD				
			DIM TOL	审核 CHECK					
			X.X ±0.30	批准 APPROVAL		产品名称 TITLE	网络插座 (卧插 带灯无弹 左绿 右黄 TAB-UP 1x1 100BASE)	版本 REV.	A
1	初版发行		X.XX ±0.20	比例 SCALE		产品料号 PART NO.	HC612601A-M411-A	单位 UNITS	mm
序号 No.	变更内容 MODIFY CONTENT	日期 MODIFY DATE	X.XXX ±0.10	投影 Projection		材料 MATERIAL		页次 SHEET	4/4
			Angle ±3.0°						