

TOP VIEW

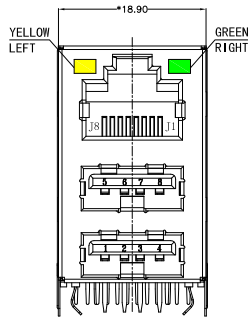

FRONT VIEW

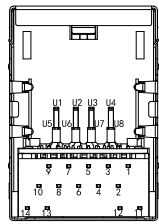

BOTTOM VIEW

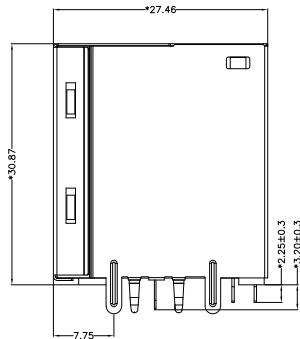

RIGHT SIDE VIEW

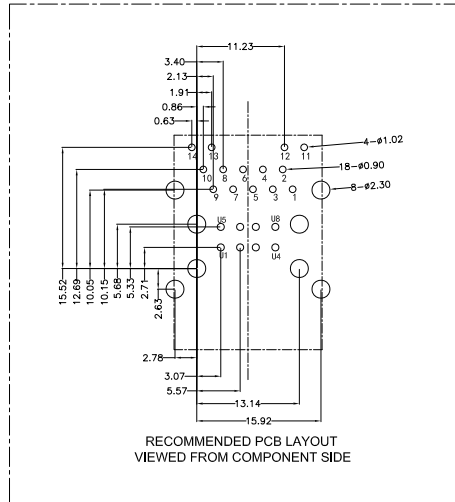

RECOMMENDED PCB LAYOUT
VIEWED FROM COMPONENT SIDE

MATERIAL:

HOUSING: PBT,UL94V-0,BLACK.
TERMINALS BRACKET: PBT,UL94V-0,BLACK.
USB HOUSING: PBT,UL94V-0,BLACK.
SHIELD: SUS304.

TERMINAL: PHOSPHOR BRONZE C5191,T=0.35MM,
6U" GOLD PLATING ON CONTACT AREA.
USB TERMINAL: BRASS,T=0.25MM,
G/FU" GOLD PLATING ON CONTACT AREA.

MECHANICAL:

DURABILITY: 750 CYCLES MIN.
MATING FORCE: 23N MAX.
OPERATING TEMPERATURE: -40°C~+85°C.
STORAGE TEMPERATURE: -40°C~+85°C.
ALL CRITICAL DIMENSIONS WITH "*"

Ordering Information

HC 6* * * ** A - M*** - 2 ** - A

- | | | | | | | |
|--------|-----------|-----|-------|------|----|-----------|
| Type | LED Color | EMI | Ports | 产品序号 | 双层 | USB |
| ①=塑料壳体 | ①=红 | ①=无 | ①=1口 | | | U2=USB2.0 |
| ②=金属壳体 | ②=蓝 | ②=有 | ②=2口 | | | U3=USB3.0 |
| ③=金属片 | ③=绿 | ③=有 | ③=1口 | | | |
| ④=金属片 | ④=黄 | ④=有 | ④=1口 | | | |
| ⑤=金属片 | ⑤=绿 | ⑤=有 | ⑤=1口 | | | |
| ⑥=金属片 | ⑥=黄 | ⑥=有 | ⑥=1口 | | | |
| | | | ⑦=1口 | | | |
| | | | ⑧=1口 | | | |
| | | | ⑨=1口 | | | |
| | | | ⑩=1口 | | | |
| | | | ⑪=1口 | | | |
| | | | ⑫=1口 | | | |
| | | | ⑬=1口 | | | |
| | | | ⑭=1口 | | | |
| | | | ⑮=1口 | | | |
| | | | ⑯=1口 | | | |
| | | | ⑰=1口 | | | |
| | | | ⑱=1口 | | | |
| | | | ⑲=1口 | | | |
| | | | ⑳=1口 | | | |

			GENERL TOLERANCE	制图	深圳市华灿天禄电子有限公司			
			DIM TOL	DRAWING	ShenzhenhuacantianluELECTRONICS CO., LTD			
			X.X ±0.30	审核	产品名称	网络插座 (三合一 卧插 带灯无弹)	版本	A
			X.XX ±0.20	CHECK	TITLE	左黄 右绿 1x1 100BASE+双USB2.0)	REV.	
			X.XXX ±0.10	批准	产品料号	HC611601A-M419-2U2-A	单位	mm
序号	变更内容	日期	Angle ±3.0°	投影	PART NO.		页次	1/4
No.	MODIFY CONTENT	MODIFY DATE		Projection	MATERIAL		SHEET	

Suggested Panel Opening:

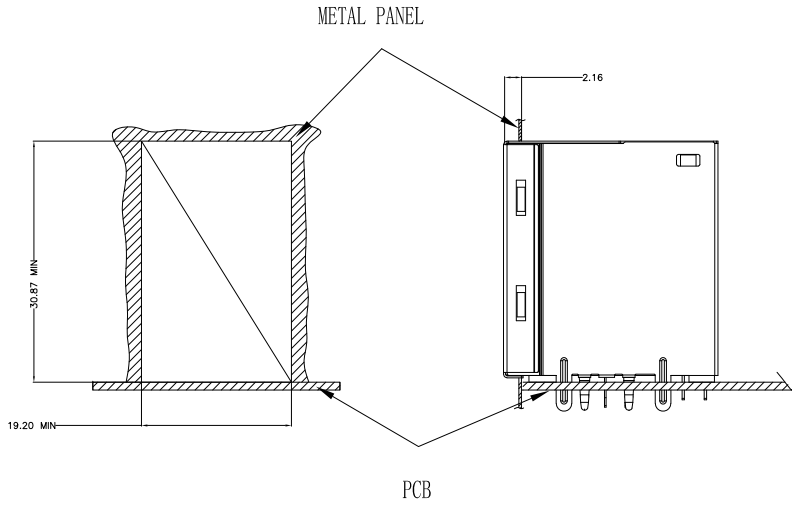

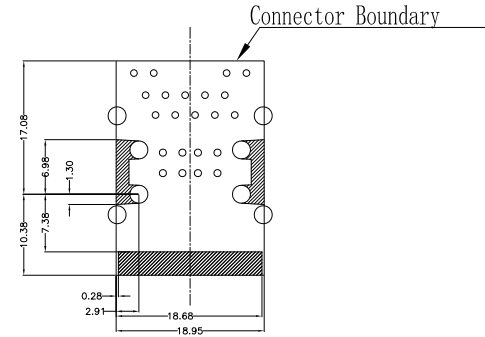

UNIT: mm / inch
Tolerances: $\pm 0.10 / 0.004$

Keep-Out Area (Component Side View):



Plug In Side

UNIT: mm / inch
Tolerances: $\pm 0.10 / 0.004$

			GENEAL TOLERANCE	制图 DRAWING	 深圳市华灿天禄电子有限公司 ShenzhenhuacantianluELECTRONICS CO., LTD			
			DIM TOL	审核 CHECK				
			X.X ± 0.30	批准 APPROVAL	产品名称 TITLE	网络插座 (三合一 卧插 带灯无弹 左黄 右绿 1x1 100BASE+双USB2.0)	版本 REV.	A
			X.XX ± 0.20	比例 SCALE	产品料号 PART NO.	HC611601A-M419-2U2-A	单位 UNITS	mm
			X.XXX ± 0.10	投影 Projection	材料 MATERIAL		页次 SHEET	2/4
序号 No.	变更内容 MODIFY CONTENT	日期 MODIFY DATE	Angle $\pm 3.0^\circ$					

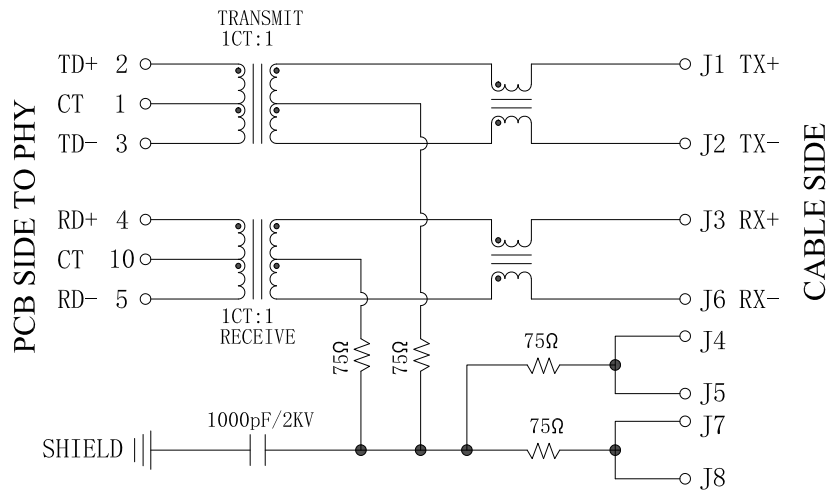

Electrical:

1. Turn ratio: 2~3: J1~J2=1CT:1CT(±2%),
4~5: J3~J6=1CT:1CT(±2%).
2. OCL: 350uH Min. at 100KHz 100mV 8mA DC.
3. Insertion Loss: -1.2 dB Max 1~100MHz.
4. Return loss: -16dB Min 1~30MHz;
-12dB Min 30~60MHz;
-10dB Min 60~80MHz.
5. Cross talk: -30dB Min 1~100MHz;
6. CMR: -30dB Min 1~100MHz;
7. Hi-Pot: 1500V AC & 2250V DC
6S 1mA PRI TO SEC

LED Specification

Standard LED Color	LED Wavelength	Foward(A)	Foward(V)
Green	565nm	20mA	2.2-2.4V
Yellow	590nm	20mA	2.1-2.5V

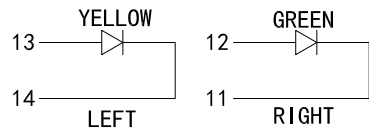

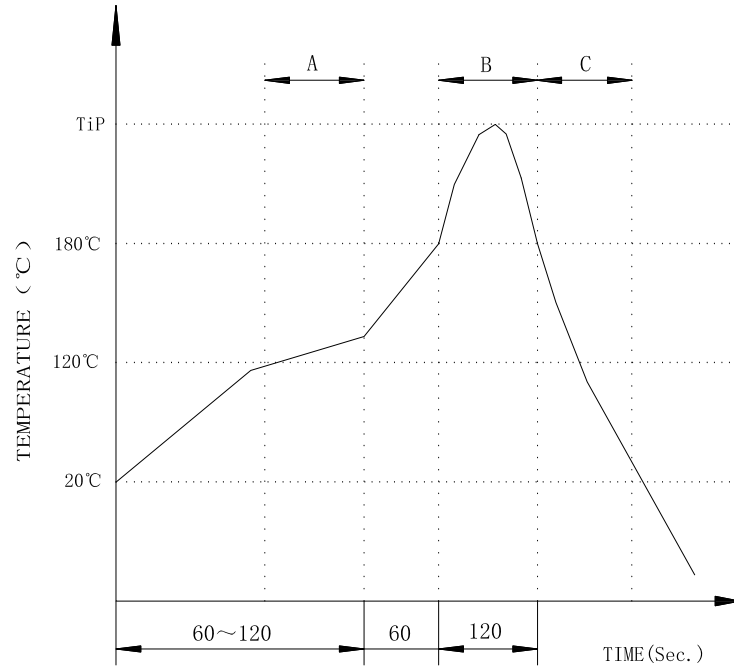

			GENEAL TOLERANCE	制图 DRAWING	深圳市华灿天禄电子有限公司 ShenzhenhuacantianluELECTRONICS CO., LTD			
			DIM TOL	审核 CHECK				
			X. X ±0.30	批准 APPROVAL	产品名称 TITLE	网络插座 (三合一 卧插 带灯无弹 左黄 右绿 1x1 100BASE+双USB2.0)	版本 REV.	A
1	初版发行		X. XX ±0.20	比例 SCALE	产品料号 PART NO.	HC611601A-M419-2U2-A	单位 UNITS	mm
序号 No.	变更内容 MODIFY CONTENT	日期 MODIFY DATE	X. XXX ±0.10	投影 Projection	材料 MATERIAL		页次 SHEET	3/4
			Angle ±3.0°					

PROFILE OF WAVE SOLDER



A.Preheating B.Soldering C.Gradual Cooling
 Tip temperature:260±5°C.
 Tip temperature time:5Sec Max.
 Tip melting point of Sn96.5/Ag3/Cu0.5:217°C.

Remarks: after wave soldering, the plastic positioning columns of the product which under the PCB will be slightly melted, but it won't affect its function.

			GENE RL TOLERANCE	制 图 DRAWING	 深圳市华灿天禄电子有限公司 ShenzhenhuacantianluELECTRONICS CO., LTD				
			DIM TOL	审 核 CHECK					
			X. X ±0.30	批 准 APPROVAL		产品名称 TITLE	网络插座 (三合一 卧插 带灯无弹 左黄 右绿 1x1 100BASE+双USB2.0)	版 本 REV.	A
1	初版发行		X. XX ±0.20	比 例 SCALE		产品料号 PART NO.	HC611601A-M419-2U2-A	单 位 UNITS	mm
序号 No.	变更内容 MODIFY CONTENT	日期 MODIFY DATE	X. XXX ±0.10	投 影 Projection		材 料 MATERIAL		页 次 SHEET	4/4
			Angle ±3.0°						