

MATERIAL:

HOUSING: LCP,UL94V-0,BLACK.
 TERMINALS BRACKET: PA46,UL94V-0,BLACK.
 SHIELD: C2680,T=0.20MM,NICKEL PLATING ON ALL AREA.
 TERMINAL: PHOSPHOR BRONZE C5210,T=0.35MM,
 6U" GOLD PLATING ON CONTACT AREA.

MECHANICAL:

DURABILITY: 750 CYCLES MIN.
 MATING FORCE: 23N MAX.
 OPERATING TEMPERATURE: -40°C~+85°C.
 STORAGE TEMPERATURE: -40°C~+85°C.
 ALL CRITICAL DIMENSIONS WITH "*"

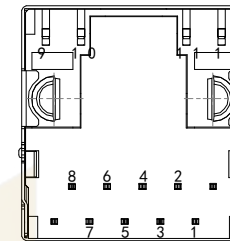
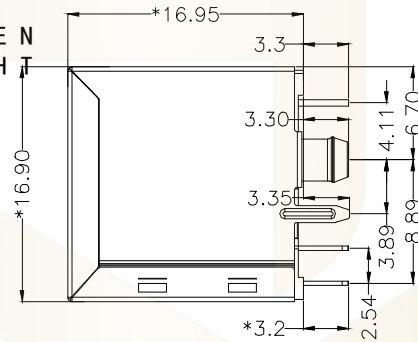
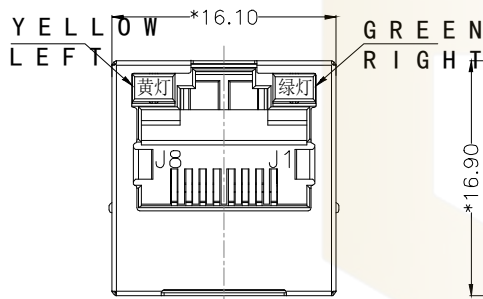

			GENERL TOLERANCE		制 图 DRAWING		深圳市华灿天禄电子有限公司 ShenzhenhuacantianluELECTRONICS CO.,LTD				
			DIM	TOL	审 核 CHECK		产品名称 TITLE		网络插座 (立式 带前腿 10/100BASE)	版本 REV.	A
			X.X	±0.30	批 准 APPROVAL		产品料号 PART NO.		HC-RJ45-511B-1-2-Q-1	单 位 UNITS	mm
1			初版发行		比 例 SCALE		投 影 Projection				
序号 No.	变更内容 MODIFY CONTENT	日期 MODIFY DATE	Angle ±3.0°		材 料 MATERIAL		页 次 SHEET		1/4		

Suggested Panel Opening:

Keep-Out Area (Component Side View):

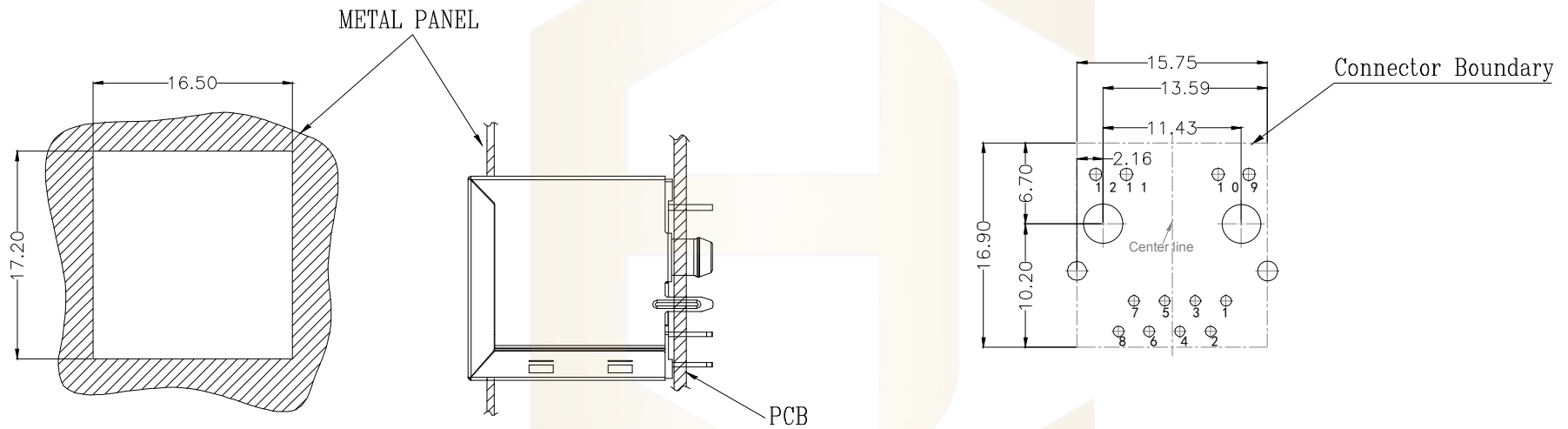

UNIT: mm / inch
Tolerances: ± 0.10 / 0.004

UNIT: mm / inch
Tolerances: ± 0.10 / 0.004

			GENERAL TOLERANCE		制图 DRAWING		深圳市华灿天禄电子有限公司 ShenzhenhuacantianluELECTRONICS CO., LTD				
			DIM	TOL	审核 CHECK		产品名称 TITLE		网络插座 (立式 带前腿 10/100BASE)	版本 REV.	A
			X.X	± 0.30	批准 APPROVAL		产品料号 PART NO.		HC-RJ45-511B-1-2-Q-1	单位 UNITS	mm
1			初版发行				投影 Projection		材料 MATERIAL		
序号 No.	变更内容 MODIFY CONTENT	日期 MODIFY DATE	Angle $\pm 3.0^\circ$		材料 MATERIAL		页次 SHEET		2/4		

PCB SIDE TO PHY

CABLE SIDE

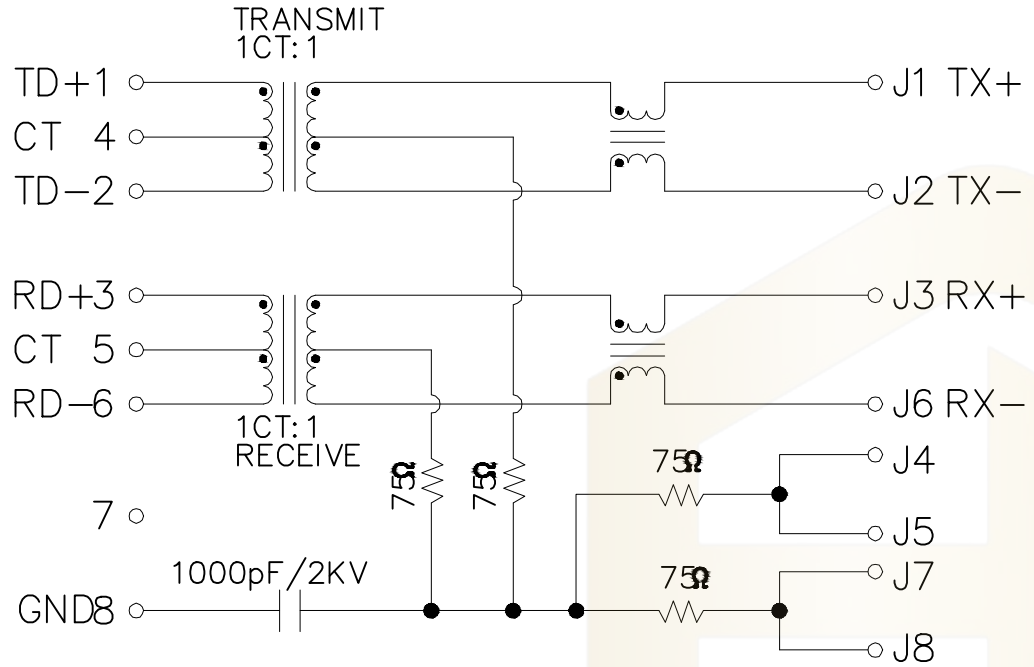

Electrical:

1. Turn ratio: 1~2: J1~J2=1CT:1CT(±2%).
3~6: J3~J6=1CT:1CT(±2%).
2. OCL: 350uH Min. at 100KHz 100mV 8mA DC.
3. Insertion Loss: -1.0 dB Max 1~100MHz.
4. Return loss: -20dB Min 1~10MHz;
-16dB Min 10~30MHz;
-12dB Min 30~60MHz;
-10dB Min 60~80MHz.
5. Cross talk: -40dB Min 1~30MHz;
-35dB Min 30~60MHz;
-30dB Min 60~100MHz;
6. CMR: -30dB Min 1~100MHz;
7. Hi-Pot: 1500V AC & 2250V DC
6S 1mA PRI TO SEC

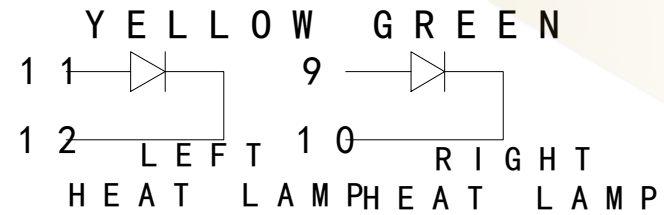

LED Specification

Standard LED Color	LED Wavelength	Foward(A)	Foward(V)
Green	568nm	20mA	1.85-2.45V
Yellow	585nm	20mA	1.7-2.2V

		GENREL TOLERANCE		制图 DRAWING	深圳市华灿天禄电子有限公司 ShenzhenhuacantianluELECTRONICS CO., LTD			
		DIM	TOL	审核 CHECK	产品名称 TITLE	网络插座 (立式 带前腿 10/100BASE)	版本 REV.	A
		X. X	±0.30	批准 APPROVAL	产品料号 PART NO.	HC-RJ45-511B-1-2-Q-1	单位 UNITS	mm
1	初版发行	X. XX	±0.20	比例 SCALE				
序号 No.	变更内容 MODIFY CONTENT	X. XXX	±0.10	投影 Projection	材料 MATERIAL	页次 SHEET		3/4
	日期 MODIFY DATE	Angle	±3.0°					

PROFILE OF REFLOW SOLDERING

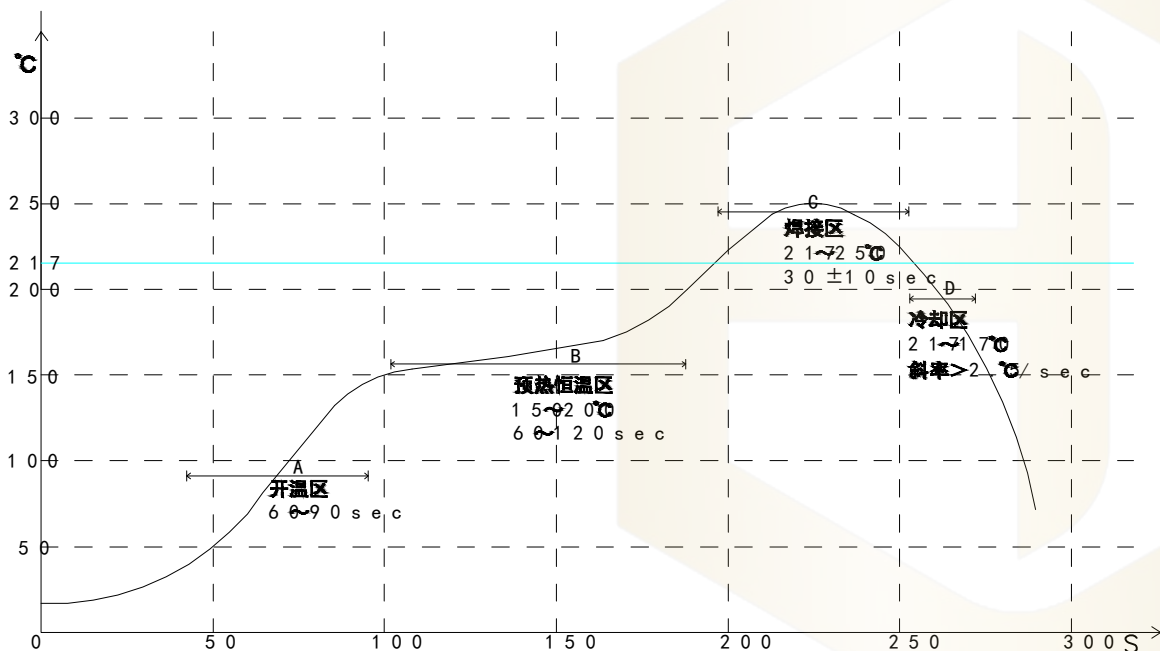

- A. Temperature range of open
 - B. Preheat temperature zone
 - C. The welding zone
 - D. The cooling zone
- Tip temperature: $265 \pm 5^{\circ}\text{C}$.
 Tip temperature time: $30 \pm 10\text{s}$
 Tip melting point of Sn96.5/Ag3/Cu0.5.

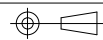
			GENERAL TOLERANCE		制 图 DRAWING		 深圳市华灿天禄电子有限公司 ShenzhenhuacantianluELECTRONICS CO., LTD				
			DIM	TOL	审 核 CHECK		产品名称 TITLE		网络插座 (立式 带前腿 10/100BASE)	版本 REV.	A
			X. X	±0.30	批 准 APPROVAL		产品料号 PART NO.		HC-RJ45-511B-1-2-Q-1	单 位 UNITS	mm
1 初版发行			X. XX	±0.20	比 例 SCALE		投 影 Projection				
序号 No.	变更内容 MODIFY CONTENT	日期 MODIFY DATE	X. XXX	±0.10	材 料 MATERIAL		页 次 SHEET		4/4		
			Angle	±3.0°							