

MATERIAL:

HOUSING: PBT,UL94V-0,BLACK.
TERMINALS BRACKET: PBT,UL94V-0,BLACK.

TERMINAL: PHOSPHOR BRONZE C5210,T=0.35MM,
6U" GOLD PLATING ON CONTACT AREA.

MECHANICAL:

DURABILITY: 750 CYCLES MIN.
MATING FORCE: 23N MAX.
OPERATING TEMPERATURE: -40°C~+85°C.
STORAGE TEMPERATURE: -40°C~+85°C.
ALL CRITICAL DIMENSIONS WITH "*"*

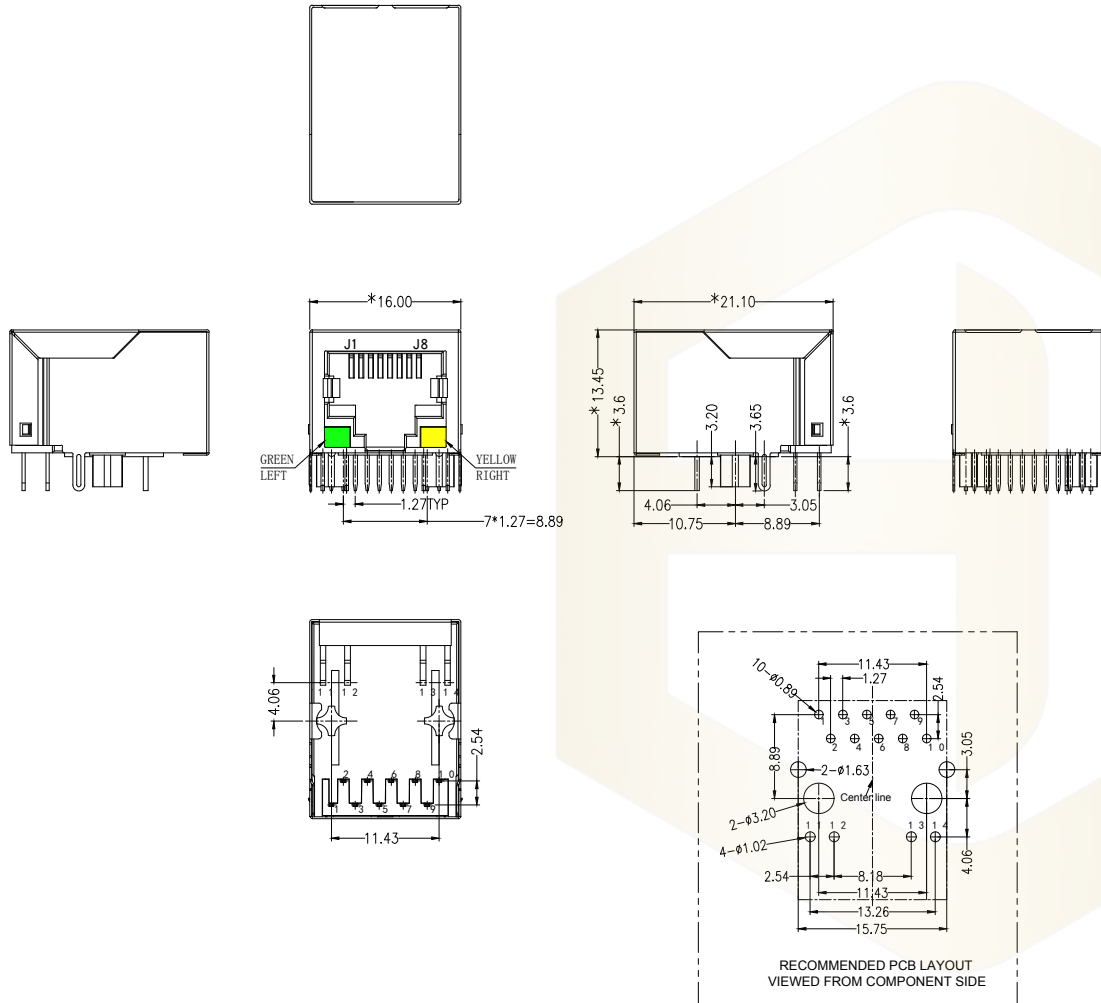

Ordering Information

HC 61 * * 01 A - M940 - A

Type	LED Color	EMI	产品序号
01-卧式插件 02-立式插件 03-卧式贴片 04-立式贴片	0-无灯 1-带灯 (左黄右绿) 2-带灯 (左绿右黄) 3-带灯 (左绿右蓝) 4-带灯 (左蓝右绿)	0-无弹 1-带弹	

			GENERAL TOLERANCE	制图 DRAWING	深圳市华灿天禄电子有限公司 ShenzhenhuacantianluELECTRONICS CO.,LTD			
			DIM TOL	审核 CHECK	产品名称 TITLE	网络插座 (卧插 带灯无弹 TAB-DOWN 1X1 2.5G)	版本 REV.	A
			X.X ±0.30	批准 APPROVAL	产品料号 PART NO.	HC612601A-M940-A	单位 UNITS	mm
			X.XX ±0.20	比例 SCALE	材料 MATERIAL		页次 SHEET	1/4
			X.XXX ±0.10	投影 Projection				
序号 No.	变更内容 MODIFY CONTENT	日期 MODIFY DATE	Angle ±3.0°					

RECOMMENDED PANEL CUTOUT (REFERENCE ONLY) :

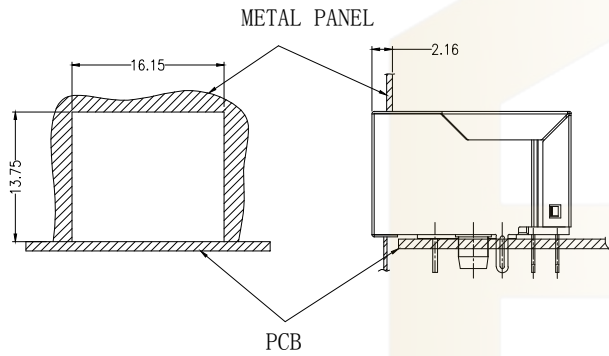

UNIT: MM / INCH
TOLERANCES: ± 0.10 / 0.004
REFERENCE ONLY

KEEP-OUT AREA (COMPONENT SIDE VIEW) :

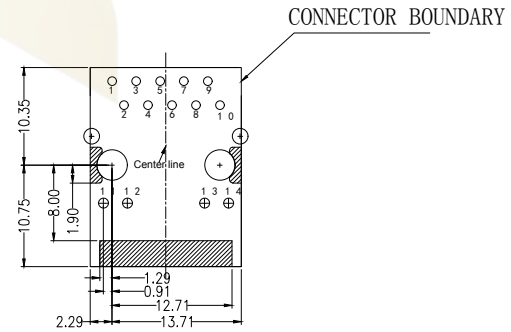

PLUG-IN SIDE

UNIT: MM / INCH
TOLERANCES: ± 0.10 / 0.004

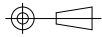
			GENERAL TOLERANCE	制图 DRAWING	 深圳市华灿天禄电子有限公司 ShenzhenhuacantianluELECTRONICS CO.,LTD				
			DIM TOL	审核 CHECK		产品名称 TITLE	网络插座 (卧插 带灯无弹 TAB-DOWN 1X1 2.5G)	版本 REV.	A
			X.X ± 0.30	批准 APPROVAL		产品料号 PART NO.	HC612601A-M940-A	单位 UNITS	mm
1	初版发行		X.XX ± 0.20	比例 SCALE		材料 MATERIAL		页次 SHEET	2/4
序号 No.	变更内容 MODIFY CONTENT	日期 MODIFY DATE	Angle $\pm 3.0^\circ$	投影 Projection					

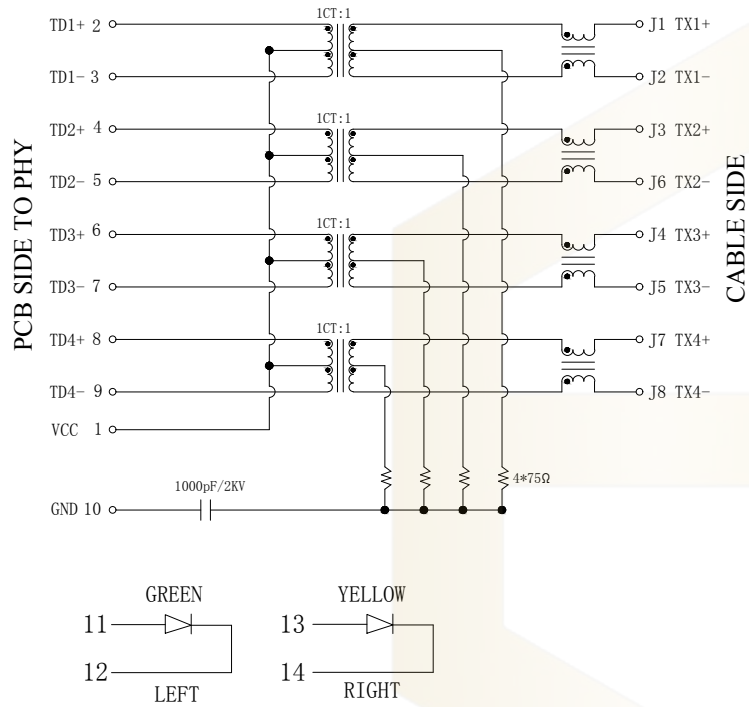

Electrical:

- Turn ratio: 2~3: J1~J2=1CT:1CT(±2%).
4~5: J3~J6=1CT:1CT(±2%).
6~7: J4~J5=1CT:1CT(±2%).
8~9: J7~J8=1CT:1CT(±2%).
- OCL: 180uH Min. @ 100KHz 0.1V.
- Insertion Loss: -1.0 dB Max 1~125MHz.
- Return loss: -20dB Min 1 ~ 40MHz;
-20+15LOG₁₀(f/40MHz) Min 40~200MHz.
- Cross talk: -30dB Min 1~125MHz.
- CMR: -30dB Min 30~200MHz;
- Hi-Pot: 2250V DC 6S 1mA PRI TO SEC

LED Specification

Standard LED Color	LED Wavelength	Foward(A)	Foward(V)
Green	568nm	20mA	1.85-2.45V
Yellow	585nm	20mA	1.7-2.2V

			GENERAL TOLERANCE	制图 DRAWING	深圳市华灿天禄电子有限公司 ShenzhenhuacantianluELECTRONICS CO., LTD			
			DIM TOL	审核 CHECK				
			X.X ±0.30	批准 APPROVAL	产品名称 TITLE	网络插座 (卧插 带灯无弹 TAB-DOWN 1X1 2.5G)	版本 REV.	A
1	初版发行		X.XX ±0.20	比例 SCALE	产品料号 PART NO.	HC612601A-M940-A	单位 UNITS	mm
序号 No.	变更内容 MODIFY CONTENT	日期 MODIFY DATE	Angle ±3.0°	投影 Projection	材料 MATERIAL		页次 SHEET	3/4

PROFILE OF WAVE SOLDER

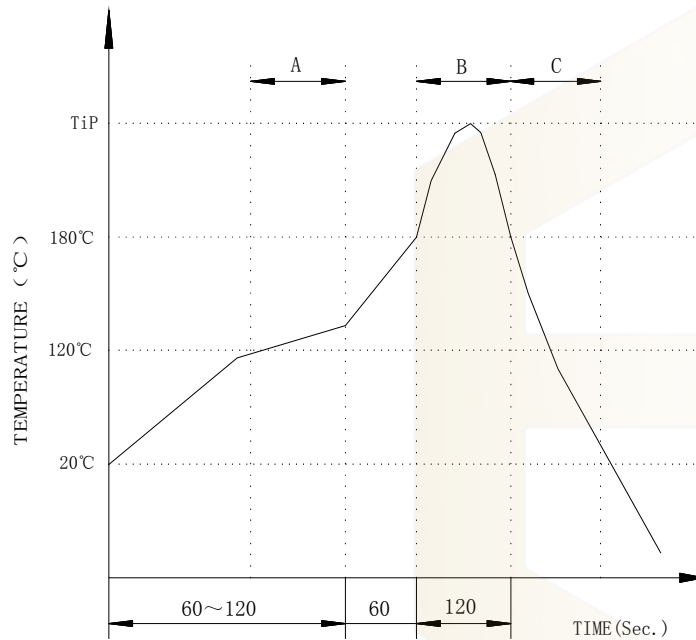

A. Preheating B. Soldering C. Gradual Cooling
 Tip temperature: $260 \pm 5^\circ \text{C}$.
 Tip temperature time: 5Sec Max.
 Tip melting point of Sn96.5/Ag3/Cu0.5: 217°C .

Remarks: after wave soldering, the plastic positioning columns of the product which under the PCB will be slightly melted, but it won't affect its function.

			GENERAL TOLERANCE	制图 DRAWING	 深圳市华灿天禄电子有限公司 ShenzhenhuaciantianluELECTRONICS CO.,LTD			
			DIM TOL	审核 CHECK				
			X.X ±0.30	批准 APPROVAL	产品名称 TITLE	网络插座 (卧插 带灯无弹 TAB-DOWN 1X1 2.5G)	版本 REV.	A
1	初版发行		X.XX ±0.20	比例 SCALE	产品料号 PART NO.	HC612601A-M940-A	单位 UNITS	mm
序号 No.	变更内容 MODIFY CONTENT	日期 MODIFY DATE	Angle ±3.0°	投影 Projection	材料 MATERIAL		页次 SHEET	4/4