

MATERIAL:
 HOUSING: PBT,UL94V-0,BLACK.
 TERMINALS BRACKET: PBT,UL94V-0,BLACK.
 SHIELD: C2680,T=0.20MM,NICKEL PLATING ON ALL AREA.
 TERMINAL: PHOSPHOR BRONZE C5210,T=0.35MM,
 6U" GOLD PLATING ON CONTACT AREA.

MECHANICAL:
 DURABILITY: 750 CYCLES MIN.
 MATING FORCE: 23N MAX.
 OPERATING TEMPERATURE: -40°C~+85°C.
 STORAGE TEMPERATURE: -40°C~+85°C.
 ALL CRITICAL DIMENSIONS WITH "**"

Ordering Information

HC 61 * * 01 A - M937 - A

| | | | |
|--|--|------------------|------|
| Type | LED Color | EMI | 产品序号 |
| 61-卧式插片 62-立式插片 63-卧式插片 64-立式插片 | 0-无灯 1-带灯 (左绿右绿) 2-带灯 (左绿右黄) 3-带灯 (左绿右蓝) 4-带灯 (左绿右橙) | 0-无EMI 7-带EMI | |

| | | | | | | | | |
|-----------|------------------------|-------------------|-------------------|------------------|---|--------------------------------------|-------------|-----|
| | | | GENERAL TOLERANCE | 制图 DRAWING | 深圳市华灿天禄电子有限公司 ShenzhenhuacantianluELECTRONICS CO.,LTD | | | |
| | | | DIM TOL | 审核 CHECK | | | | |
| | | | X.X ±0.30 | 批准 APPROVAL | 产品名称 TITLE | 网络插座 (卧插 带灯无弹 TAB-UP 1X2 100BASE) | 版本 REV. | A |
| 1 | 初版发行 | | X.XX ±0.20 | 比例 SCALE | 产品料号 PART NO. | HC611601A-M937-A | 单位 UNITS | mm |
| 序号 No. | 变更内容 MODIFY CONTENT | 日期 MODIFY DATE | X.XXX ±0.10 | 投影 Projection | 材料 MATERIAL | | 页次 SHEET | 1/4 |
| | | | Angle ±3.0° | | | | | |

RECOMMENDED PANEL CUTOUT (REFERENCE ONLY):

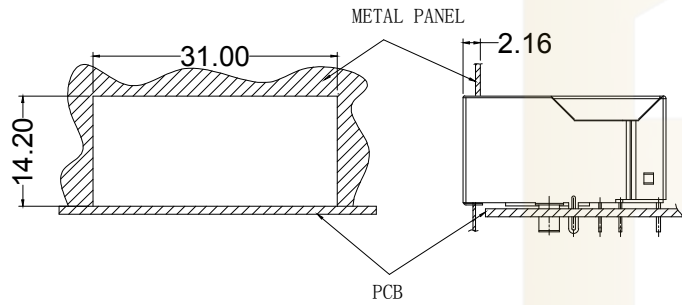

UNIT: MM / INCH
TOLERANCES: $\pm 0.10 / 0.004$
REFERENCE ONLY

KEEP-OUT AREA (COMPONENT SIDE VIEW):

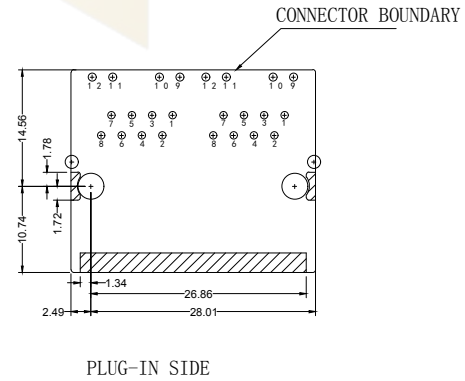

UNIT: MM / INCH
TOLERANCES: $\pm 0.10 / 0.004$

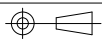
| | | | | | | | | | |
|-----------|------------------------|-------------------|-----------------------|------------------|---|------------------|--------------------------------------|-------------|-----|
| | | | GENERAL TOLERANCE | 制图 DRAWING |  深圳市华灿天禄电子有限公司 ShenzhenhuacantianluELECTRONICS CO., LTD | | | | |
| | | | DIM TOL | 审核 CHECK | | | | | |
| | | | X.X ± 0.30 | 批准 APPROVAL | | 产品名称 TITLE | 网络插座 (卧插 带灯无弹 TAB-UP 1X2 100BASE) | 版本 REV. | A |
| | | | X.XX ± 0.20 | 比例 SCALE | | 产品料号 PART NO. | HC611601A-M937-A | 单位 UNITS | mm |
| | | | X.XXX ± 0.10 | 投影 Projection |  | 材料 MATERIAL | | 页次 SHEET | 2/4 |
| 1 | 初版发行 | | Angle $\pm 3.0^\circ$ | | | | | | |
| 序号 No. | 变更内容 MODIFY CONTENT | 日期 MODIFY DATE | | | | | | | |

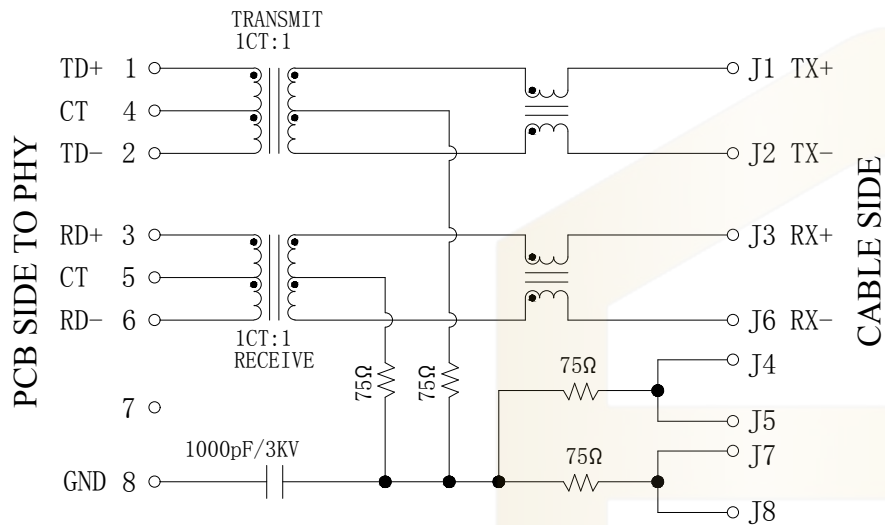

Electrical:

1. Turn ratio: 1~2: J1~J2=1CT:1CT(±2%).
3~6: J3~J6=1CT:1CT(±2%).
2. OCL: 350uH Min. at 100KHz 100mV 8mA DC.
3. Insertion Loss: -1.0 dB Max 1~100MHz.
4. Return loss: -20dB Min 1~10MHz;
-16dB Min 10~30MHz;
-12dB Min 30~60MHz;
-10dB Min 60~80MHz.
5. Cross talk: -40dB Min 1~30MHz;
-35dB Min 30~60MHz;
-30dB Min 60~100MHz;
6. CMR: -30dB Min 1~100MHz;
7. Hi-Pot: 2000V AC & 2800V DC
6S 1mA PRI TO SEC

LED Specification

| Standard LED Color | LED Wavelength | Foward(A) | Foward(V) |
|--------------------|----------------|-----------|------------|
| Green | 568nm | 20mA | 1.85-2.45V |
| Yellow | 585nm | 20mA | 1.7-2.2V |

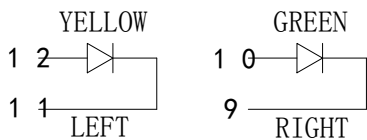

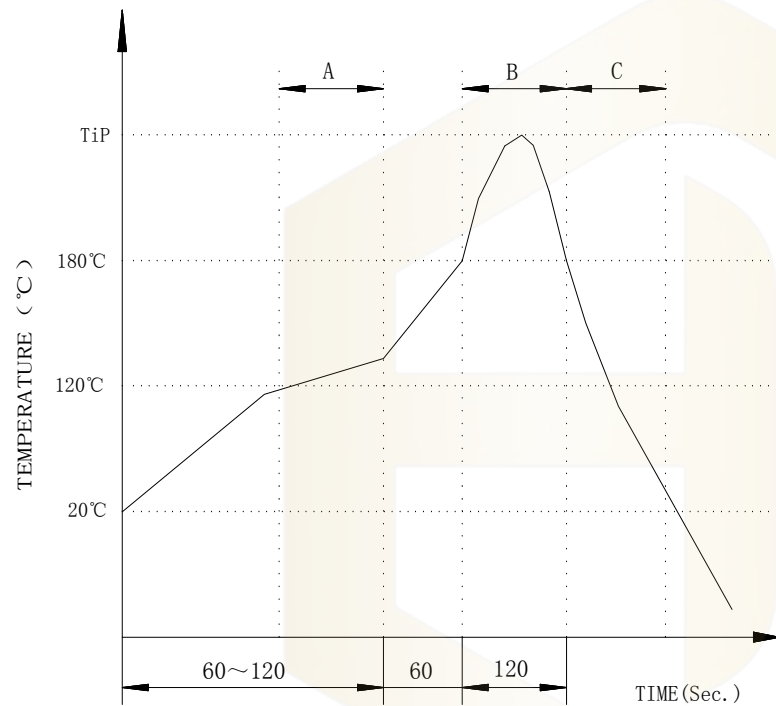

| | | | | | | | | |
|-----------|------------------------|-------------------|-------------------|------------------|---|--------------------------------------|-------------|-----|
| | | | GENEERL TOLERANCE | 制图 DRAWING | 深圳市华灿天禄电子有限公司 ShenzhenhuacantianluELECTRONICS CO., LTD | | | |
| | | | DIM TOL | 审核 CHECK | | | | |
| | | | X.X ±0.30 | 批准 APPROVAL | 产品名称 TITLE | 网络插座 (卧插 带灯无弹 TAB-UP 1X2 100BASE) | 版本 REV. | A |
| 1 | 初版发行 | | X.XX ±0.20 | 比例 SCALE | 产品料号 PART NO. | HC611601A-M937-A | 单位 UNITS | mm |
| 序号 No. | 变更内容 MODIFY CONTENT | 日期 MODIFY DATE | X.XXX ±0.10 | 投影 Projection | 材料 MATERIAL | | 页次 SHEET | 3/4 |
| | | | Angle ±3.0° | | | | | |

PROFILE OF WAVE SOLDER



A. Preheating B. Soldering C. Gradual Cooling
 Tip temperature: $260 \pm 5^\circ \text{C}$.
 Tip temperature time: 5Sec Max.
 Tip melting point of Sn96.5/Ag3/Cu0.5: 217°C .

Remarks: after wave soldering, the plastic positioning columns of the product which under the PCB will be slightly melted, but it won't affect its function.

| | | | | | | | | | |
|-----------|------------------------|-------------------|-------------------|------------------|---|------------------|---------------------------------------|-------------|-----|
| | | | GENERAL TOLERANCE | 制图 DRAWING |  深圳市华灿天禄电子有限公司 ShenzhenhuacantianluELECTRONICS CO.,LTD | | | | |
| | | | DIM TOL | 审核 CHECK | | | | | |
| | | | X.X ±0.30 | 批准 APPROVAL | | 产品名称 TITLE | 网络插座 (卧插 带灯无弹) TAB-UP 1X2 100BASE) | 版本 REV. | A |
| 1 | 初版发行 | | X.XX ±0.20 | 比例 SCALE | | 产品料号 PART NO. | HC611601A-M937-A | 单位 UNITS | mm |
| 序号 No. | 变更内容 MODIFY CONTENT | 日期 MODIFY DATE | Angle ±3.0° | 投影 Projection |  | 材料 MATERIAL | | 页次 SHEET | 4/4 |