

TOP VIEW

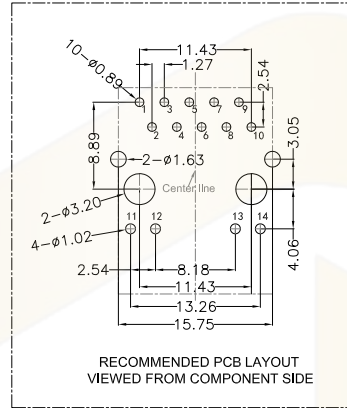

**MATERIAL:**

HOUSING: PA9T,UL94V-0,BLACK.  
 TERMINALS BRACKET: PBT,UL94V-0,BLACK.  
 SHIELD: C2680,T=0.20MM,NICKEL PLATING ON ALL AREA.  
 TERMINAL: PHOSPHOR BRONZE C5210,T=0.35MM,  
 30U" GOLD PLATING ON CONTACT AREA.

**MECHANICAL:**

DURABILITY: 750 CYCLES MIN.  
 MATING FORCE: 23N MAX.  
 OPERATING TEMPERATURE: -40°C~+85°C.  
 STORAGE TEMPERATURE: -40°C~+85°C.  
 ALL CRITICAL DIMENSIONS WITH "±"

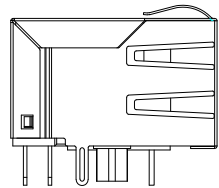

LEFT SIDE VIEW

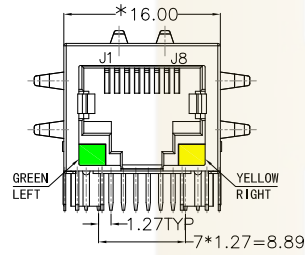

FRONT VIEW

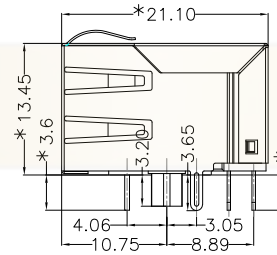

RIGHT SIDE VIEW

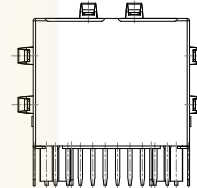

BACK VIEW

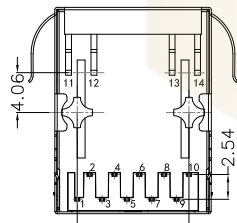

BOTTOM VIEW

**Ordering Information**

HC 6\* \* \* \* A - M\* \* \* - A

- |  |   |  |   |       |
|--|---|--|---|-------|
| Type   | LED Color   | EMI  | Ports   | 产品序号  |
| <ul style="list-style-type: none"> <li>□ 卧式插片</li> <li>□ 立式插片</li> <li>□ 卧式插片</li> <li>□ 立式插片</li> </ul> | <ul style="list-style-type: none"> <li>□ 红色</li> <li>□ 黄色 (左黄右绿)</li> <li>□ 绿色 (左绿右黄)</li> <li>□ 蓝色 (左蓝右紫)</li> <li>□ 紫色 (左紫右蓝)</li> <li>□ 白色 (左白右黑)</li> </ul> | <ul style="list-style-type: none"> <li>□ 无EMI</li> <li>□ 有EMI</li> </ul> | <ul style="list-style-type: none"> <li>□ 1个口</li> <li>□ 2个口</li> <li>□ 3个口</li> <li>□ 4个口</li> <li>□ 5个口</li> <li>□ 6个口</li> <li>□ 7个口</li> <li>□ 8个口</li> <li>□ 9个口</li> <li>□ 10个口</li> <li>□ 11个口</li> <li>□ 12个口</li> <li>□ 13个口</li> <li>□ 14个口</li> <li>□ 15个口</li> <li>□ 16个口</li> <li>□ 17个口</li> <li>□ 18个口</li> <li>□ 19个口</li> <li>□ 20个口</li> <li>□ 21个口</li> <li>□ 22个口</li> <li>□ 23个口</li> <li>□ 24个口</li> <li>□ 25个口</li> <li>□ 26个口</li> <li>□ 27个口</li> <li>□ 28个口</li> <li>□ 29个口</li> <li>□ 30个口</li> </ul> | ..... |

		GENERAL TOLERANCE		制图	深圳市华灿天禄电子有限公司			
		DIM TOL		审核	ShenzhenhuacantianluELECTRONICS CO., LTD			
		X.X ±0.30		批准	产品名称	网络插座 (卧插 带灯带弹 左绿	版本	A
		X.XX ±0.20		CHECK	TITLE	右黄 TAB-DOWN 1x1 1000BASE)	REV.	
		X.XXX ±0.10		APPROVAL	产品料号	HC612701A-M402-A	单位	mm
		Angle ±3.0°		SCALE	PART NO.		页次	1/4
序号	变更内容	日期		投影	材料		SHEET	
No.	MODIFY CONTENT	MODIFY DATE		Projection	MATERIAL			

RECOMMENDED PANEL CUTOUT (REFERENCE ONLY):

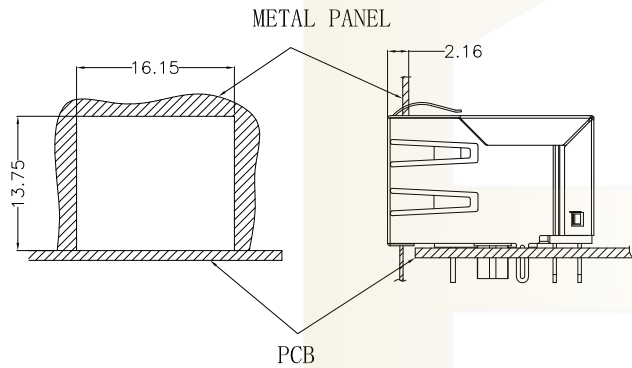

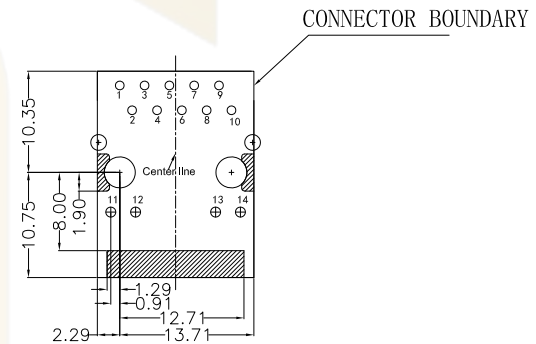

UNIT: MM / INCH  
TOLERANCES:  $\pm 0.10 / 0.004$   
REFERENCE ONLY

KEEP-OUT AREA (COMPONENT SIDE VIEW):



PLUG-IN SIDE

UNIT: MM / INCH  
TOLERANCES:  $\pm 0.10 / 0.004$

			GENERAL TOLERANCE	制图 DRAWING	 深圳市华灿天禄电子有限公司 ShenzhenhuacantianluELECTRONICS CO., LTD				
			DIM TOL	审核 CHECK		产品名称 TITLE	网络插座 (卧插 带灯带弹 左绿 右黄 TAB-DOWN 1x1 1000BASE)	版本 REV.	A
			X.X $\pm 0.30$	批准 APPROVAL		产品料号 PART NO.	HC612701A-M402-A	单位 UNITS	mm
1	初版发行		X.XX $\pm 0.20$	投影 Projection		材料 MATERIAL		页次 SHEET	2/4
序号 No.	变更内容 MODIFY CONTENT	日期 MODIFY DATE	X.XXX $\pm 0.10$						
			Angle $\pm 3.0^\circ$						

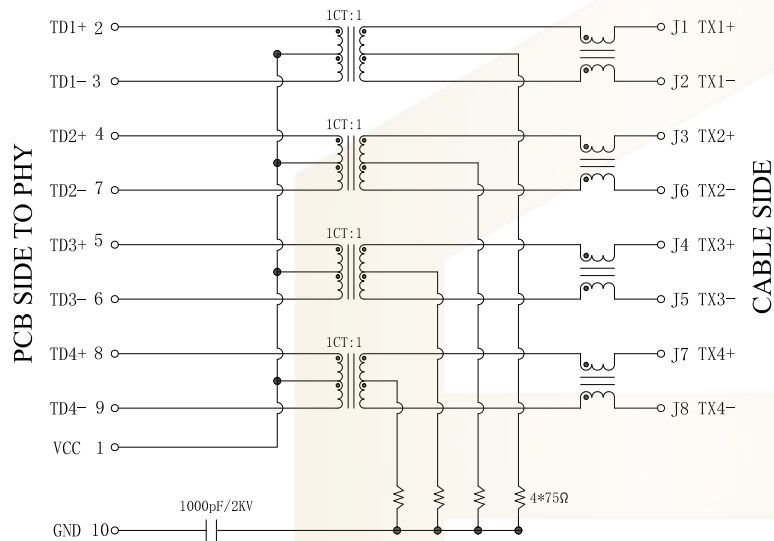

**Electrical:**

- Turn ratio: 2~3: J1~J2=1CT:1CT(±2%).  
4~7: J3~J6=1CT:1CT(±2%).  
5~6: J4~J5=1CT:1CT(±2%).  
8~9: J7~J8=1CT:1CT(±2%).
- OCL: 350uH Min. at 100KHz 100mV 8mA DC.
- Insertion Loss: -1.0 dB Max 1~100MHz.
- Return loss: -18dB Min 1~30MHz;  
-14dB Min 30~60MHz.  
-12dB Min 60~80MHz.  
-10dB Min 80~100MHz.
- Cross talk: -40dB Min 1~30MHz;  
-35dB Min 30~60MHz;  
-30dB Min 60~100MHz;
- CMR: -30dB Min 1~100MHz;
- Hi-Pot: 2250V DC 6S 1mA PRI TO SEC

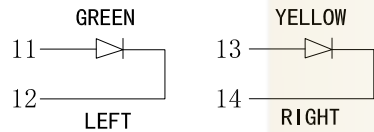

**LED Specification**

Standard LED Color	LED Wavelength	Foward(A)	Foward(V)
Green	568nm	20mA	1.85-2.45V
Yellow	585nm	20mA	1.7-2.2V

			GENERAL TOLERANCE	制图 DRAWING	深圳市华灿天禄电子有限公司 ShenzhenhuacantianluELECTRONICS CO., LTD			
			DIM TOL	审核 CHECK				
			X.X ±0.30	批准 APPROVAL	产品名称 TITLE	网络插座 (卧插 带灯带弹 左绿 右黄 TAB-DOWN 1x1 1000BASE)	版本 REV.	A
1	初版发行		X.XX ±0.20	比例 SCALE	产品料号 PART NO.	HC612701A-M402-A	单位 UNITS	mm
序号 No.	变更内容 MODIFY CONTENT	日期 MODIFY DATE	X.XXX ±0.10	投影 Projection	材料 MATERIAL		页次 SHEET	3/4
			Angle ±3.0°					

# PROFILE OF WAVE SOLDER

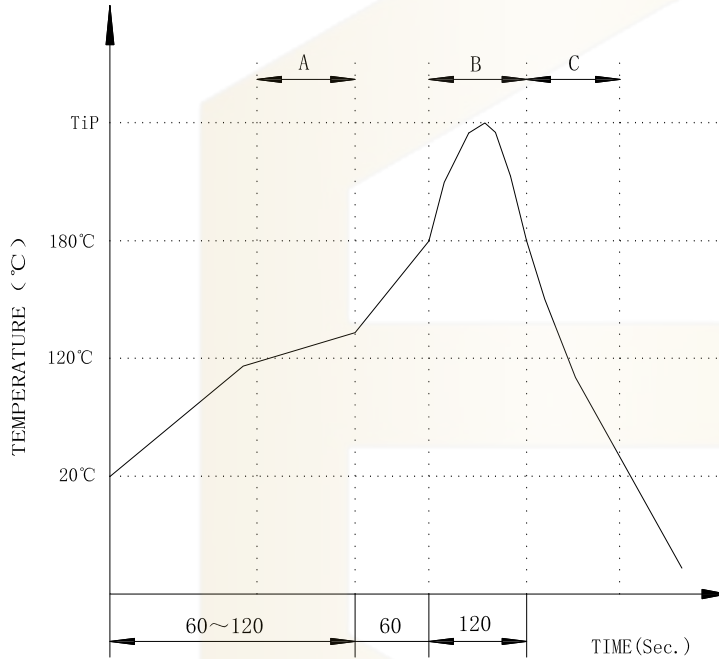

A.Preheating B.Soldering C.Gradual Cooling  
 Tip temperature:260±5°C.  
 Tip temperature time:5Sec Max.  
 Tip melting point of Sn96.5/Ag3/Cu0.5:217°C.

Remarks: after wave soldering, the plastic positioning columns of the product which under the PCB will be slightly melted, but it won't affect its function.

			GENERAL TOLERANCE	制图 DRAWING	 深圳市华灿天禄电子有限公司 ShenzhenhuacantianluELECTRONICS CO.,LTD			
			DIM TOL	审核 CHECK				
			X.X ±0.30	批准 APPROVAL	产品名称 TITLE	网络插座 (卧插 带灯带弹 左绿 右黄 TAB-DOWN 1x1 1000BASE)	版本 REV.	A
1	初版发行		X.XX ±0.20	比例 SCALE	产品料号 PART NO.	HC612701A-M402-A	单位 UNITS	mm
序号 No.	变更内容 MODIFY CONTENT	日期 MODIFY DATE	X.XXX ±0.10	投影 Projection	材料 MATERIAL		页次 SHEET	4/4
			Angle ±3.0°	