

TOP VIEW

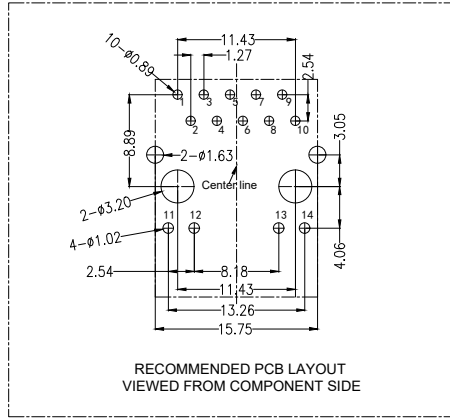

RECOMMENDED PCB LAYOUT
VIEWED FROM COMPONENT SIDE

MATERIAL:

HOUSING: PBT,UL94V-0,BLACK.
 TERMINALS BRACKET: PBT,UL94V-0,BLACK.
 SHIELD: BRASS,T=0.20MM,NICKEL PLATING ON ALL AREA.
 TERMINAL: PHOSPHOR BRONZE,T=0.35MM,
 6U" GOLD PLATING ON CONTACT AREA.

MECHANICAL:

DURABILITY: 750 CYCLES MIN.
 MATING FORCE: 23N MAX.
 OPERATING TEMPERATURE: -40°C~+85°C.
 STORAGE TEMPERATURE: -40°C~+85°C.
 ALL CRITICAL DIMENSIONS WITH "***"

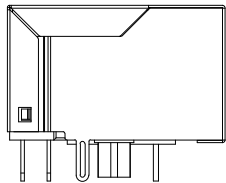

LEFT SIDE VIEW

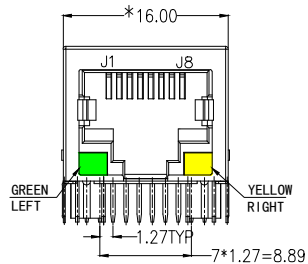

FRONT VIEW

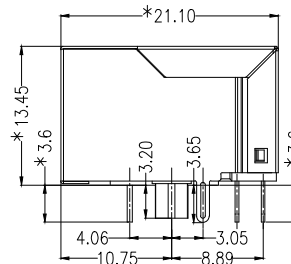

RIGHT SIDE VIEW

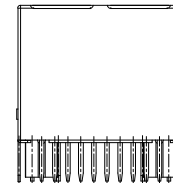

BACK VIEW

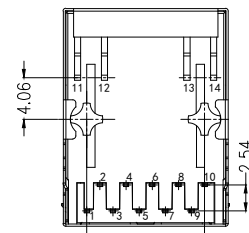

BOTTOM VIEW

Ordering Information

HC 6* * * ** A - M*** - A

Type	LED Color	EMI	Ports	产品序号
61-卧式插件	0-蓝灯	0-无弹	1-4位	
62-立式插件	1-黄灯 (左绿右黄)	7-有弹	01-1位	
63-卧式贴片	2-黄灯 (左绿右黄)	8*4位插针	02-2位	
64-立式贴片	3-黄灯 (左绿右黄)	8*4位插针 (无屏蔽)	22-2位211	
	4-黄灯 (左绿右黄)		
	5-黄灯 (左绿右黄)			
	6-黄灯 (左绿右黄)			
	7-黄灯 (左绿右黄)			
	8-黄灯 (左绿右黄)			

			GENERAL TOLERANCE	制图 DRAWING	深圳市华灿天禄电子有限公司 ShenzhenhuacantianluELECTRONICS CO.,LTD			
			DIM TOL	审核 CHECK	产品名称 TITLE	网络插座 (卧插 带灯无弹 左绿 右黄 TAB-DOWN 1X1 2.5G)	版本 REV.	A
			X.X ±0.30	批准 APPROVAL	产品料号 PART NO.	HC612601A-M418-A	单位 UNITS	mm
1	初版发行		X.XX ±0.20	比例 SCALE	材料 MATERIAL		页次 SHEET	1/4
序号 No.	变更内容 MODIFY CONTENT	日期 MODIFY DATE	X.XXX ±0.10	投影 Projection				
			Angle ±3.0°					

RECOMMENDED PANEL CUTOUT (REFERENCE ONLY) :

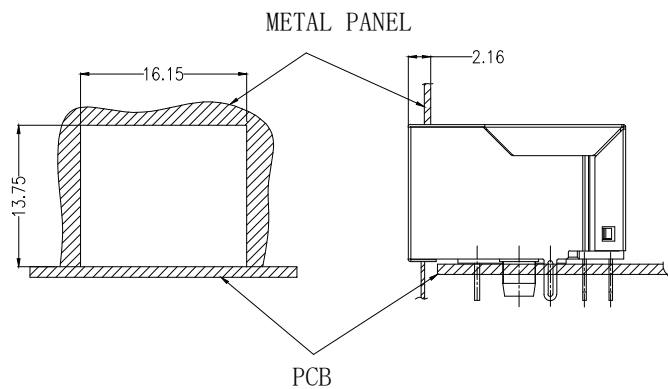

UNIT: MM / INCH
 TOLERANCES: ± 0.10 / 0.004
 REFERENCE ONLY

KEEP-OUT AREA (COMPONENT SIDE VIEW) :

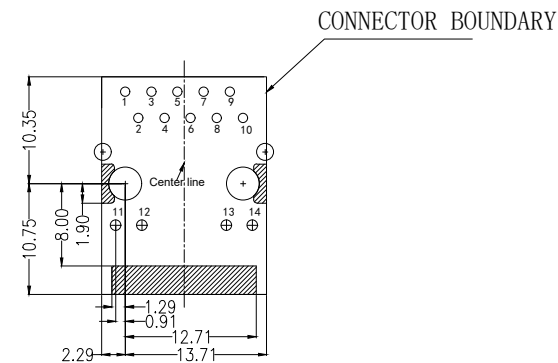

PLUG-IN SIDE

UNIT: MM / INCH
 TOLERANCES: ± 0.10 / 0.004

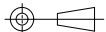
			GENERAL TOLERANCE	制图 DRAWING	 深圳市华灿天禄电子有限公司 ShenzhenhuacantianluELECTRONICS CO.,LTD			
			DIM TOL	审核 CHECK	产品名称 TITLE	网络插座 (卧插 带灯无弹 左绿 右黄 TAB-DOWN 1X1 2.5G)	版本 REV.	A
			X.X ± 0.30	批准 APPROVAL	产品料号 PART NO.	HC612601A-M418-A	单位 UNITS	mm
1	初版发行		X.XX ± 0.20	比例 SCALE	材料 MATERIAL		页次 SHEET	2/4
序号 No.	变更内容 MODIFY CONTENT	日期 MODIFY DATE	X.XXX ± 0.10	投影 Projection				
			Angle $\pm 3.0^\circ$					

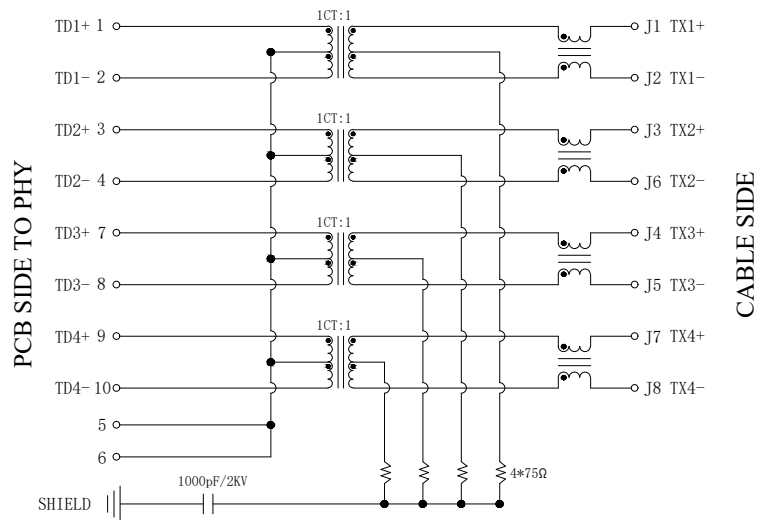

Electrical:

1. Turn ratio: 1~2: J1~J2=1CT:1CT(±2%).
3~4: J3~J6=1CT:1CT(±2%).
7~8: J4~J5=1CT:1CT(±2%).
9~10: J7~J8=1CT:1CT(±2%).
2. OCL: 180uH Min. @ 100KHz 0.1V.
3. Insertion Loss: -1.0 dB Max 1~125MHz.
4. Return loss: -20dB Min 1 ~ 40MHz;
-20+15LOG₁₀(f/40MHz) Min 40~200MHz.
5. Cross talk: -30dB Min 1~125MHz.
6. CMR: -30dB Min 30~200MHz;
7. Hi-Pot: 2250V DC 6S 1mA PRI TO SEC

LED Specification

Standard LED Color	LED Wavelength	Foward(A)	Foward(V)
Green	568nm	20mA	1.85-2.45V
Yellow	585nm	20mA	1.7-2.2V

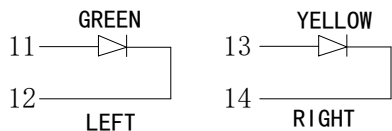

			GENREL TOLERANCE	制图 DRAWING	深圳市华灿天禄电子有限公司 ShenzhenhuacantianluELECTRONICS CO.,LTD			
			DIM TOL	审核 CHECK	产品名称 TITLE	网络插座 (卧插 带灯无弹 左绿 右黄 TAB-DOWN 1X1 2.5G)	版本 REV.	A
			X. X ±0.30	批准 APPROVAL	产品料号 PART NO.	HC612601A-M418-A	单位 UNITS	mm
1	初版发行		X. XX ±0.20	比例 SCALE	材料 MATERIAL		页次 SHEET	3/4
序号 No.	变更内容 MODIFY CONTENT	日期 MODIFY DATE	X. XXX ±0.10	投影 Projection				
			Angle ±3.0°					

PROFILE OF WAVE SOLDER

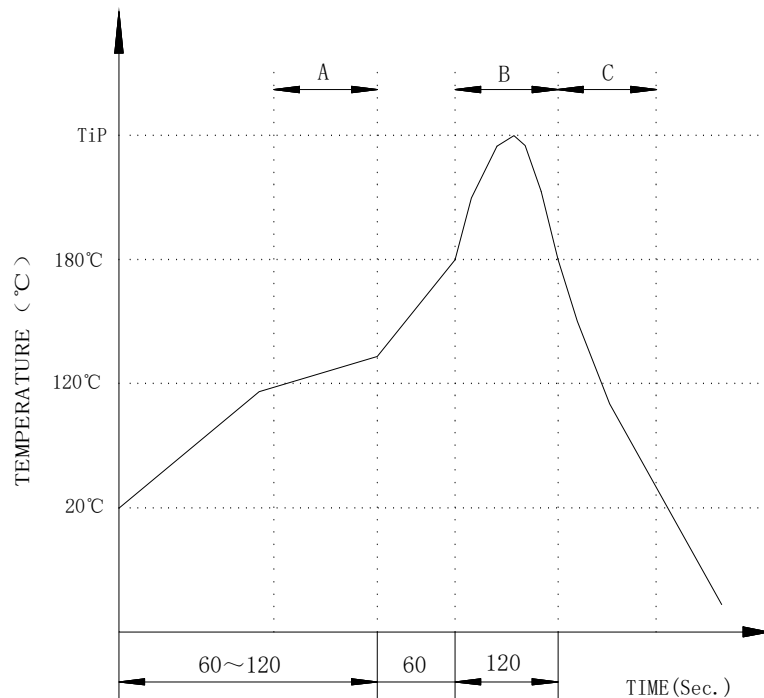

A.Preheating B.Soldering C.Gradual Cooling
 Tip temperature:260±5°C.
 Tip temperature time:5Sec Max.
 Tip melting point of Sn96.5/Ag3/Cu0.5:217°C.

Remarks: after wave soldering, the plastic positioning columns of the product which under the PCB will be slightly melted, but it won't affect its function.

			GENERL TOLERANCE	制图 DRAWING	 深圳市华灿天禄电子有限公司 ShenzhenhuacantianluELECTRONICS CO.,LTD			
			DIM TOL	审核 CHECK	产品名称 TITLE	网络插座 (卧插 带灯无弹 左绿 右黄 TAB-DOWN 1X1 2.5G)	版本 REV.	A
			X. X ±0.30	批准 APPROVAL	产品料号 PART NO.	HC612601A-M418-A	单位 UNITS	mm
1	初版发行		X. XX ±0.20	比例 SCALE	材料 MATERIAL		页次 SHEET	4/4
序号 No.	变更内容 MODIFY CONTENT	日期 MODIFY DATE	Angle ±3.0°	投影 Projection	