

SUGGESTED PANEL OPENING:

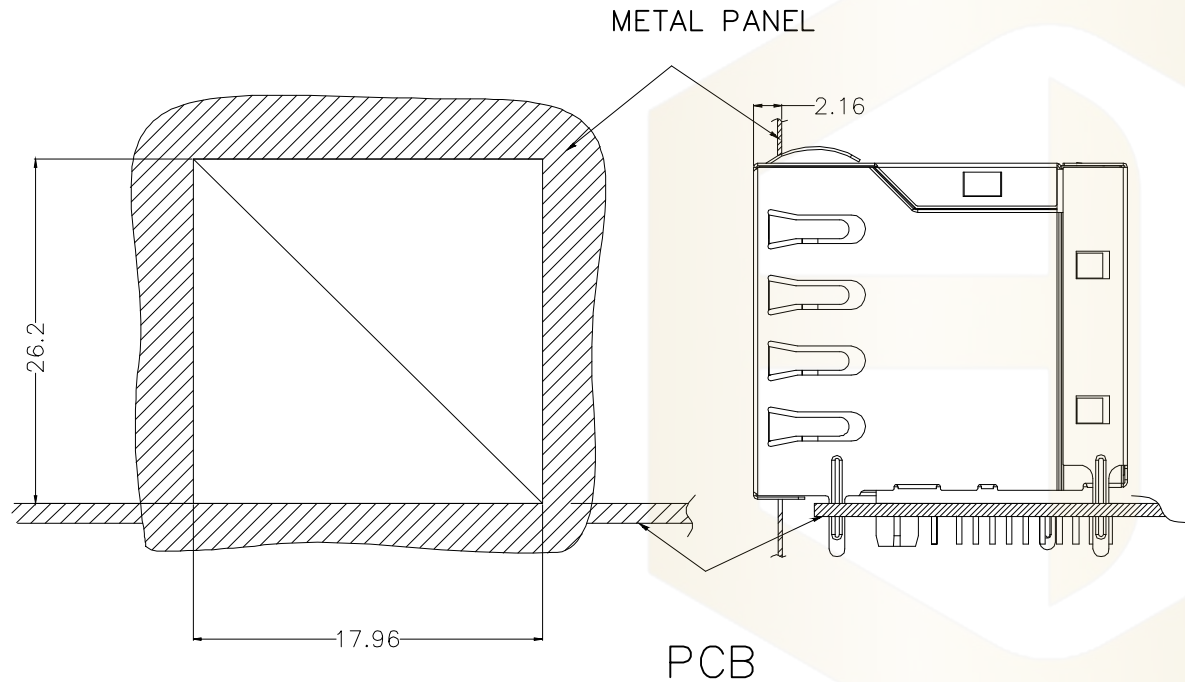

UNIT: MM / INCH
TOLERANCES: ± 0.10 / 0.004

KEEP-OUT AREA (COMPONENT SIDE VIEW):

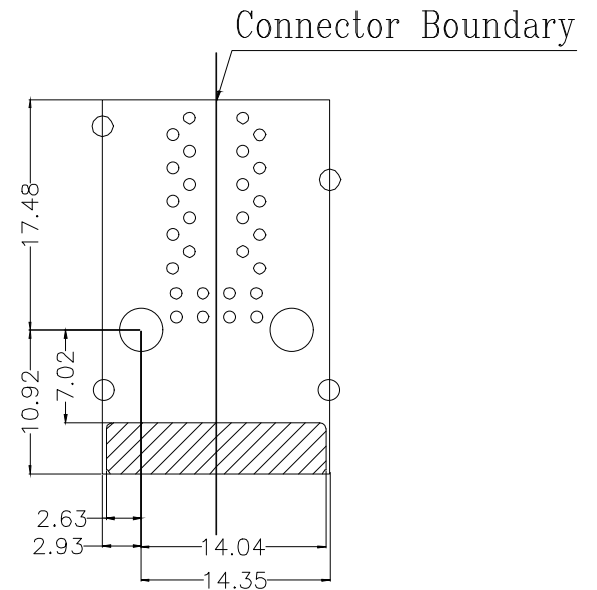

PLUG-IN SIDE

UNIT: MM / INCH
TOLERANCES: ± 0.10 / 0.004

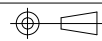
			GENERAL TOLERANCE		制图 DRAWING		深圳市华灿天禄电子有限公司 ShenzhenhuacantianluELECTRONICS CO., LTD				
			DIM	TOL	审核 CHECK		产品名称 TITLE		网络插座 (插件 2x1 10/100/1000BASE)	版本 REV.	A
			X.X	± 0.30	批准 APPROVAL		产品料号 PART NO.		HC-RJ45-21Q-2x1-1-1	单位 UNITS	mm
1			初版发行				投影 Projection				
序号 No.	变更内容 MODIFY CONTENT	日期 MODIFY DATE	Angle	$\pm 3.0^\circ$			材料 MATERIAL		页次 SHEET		

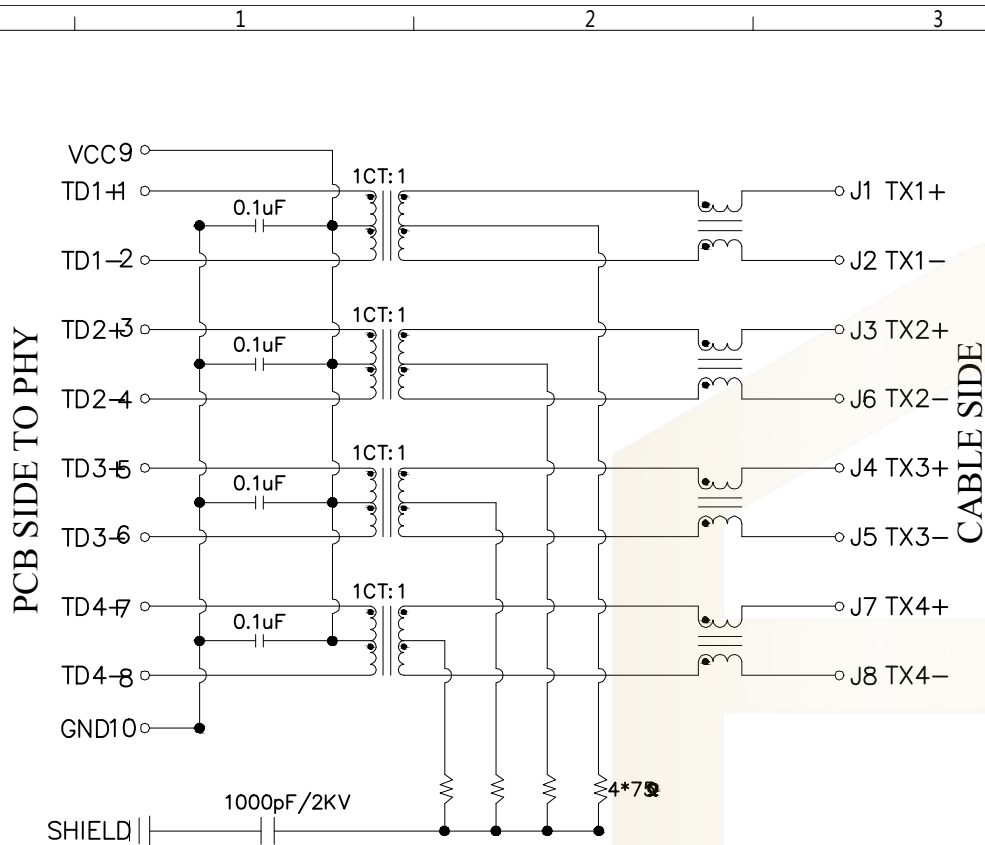

Electrical:

1. Turn ratio: 1~2: J1~J2=1CT:1CT(±2%).
3~4: J3~J6=1CT:1CT(±2%).
5~6: J4~J5=1CT:1CT(±2%).
7~8: J7~J8=1CT:1CT(±2%).
2. OCL: 350uH Min. at 100KHz 100mV 8mA DC.
3. Insertion Loss: -1.0 dB Max 1~100MHz.
-1.2 dB Max 100~125MHz.
4. Return loss: -16dB Min 1~40MHz;
-12dB Min 40~60MHz.
-10dB Min 60~80MHz.
-8dB Min 80~100MHz.
5. Cross talk: -30dB Min 1~100MHz;
6. CMR: -30dB Min 1~100MHz;
7. Hi-Pot: 2250V DC 6S 1mA PRI TO SEC

LED Specification

Standard LED Color	LED Wavelength	Foward(A)	Foward(V)
Green	565nm	20mA	2.2-2.4V
Yellow	590nm	20mA	2.1-2.5V

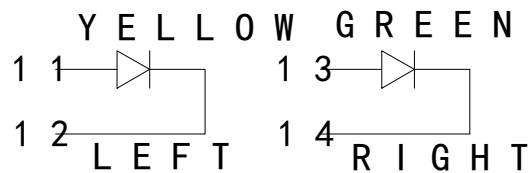

			GENREL TOLERANCE	制 图 DRAWING	深圳市华灿天禄电子有限公司 ShenzhenhuacantianluELECTRONICS CO., LTD			
			DIM TOL	审 核 CHECK	产品名称 TITLE	网络插座 (插件 2x1 10/100/1000BASE)	版本 REV.	A
			X. X ±0.30	批 准 APPROVAL	产品料号 PART NO.	HC-RJ45-21Q-2x1-1-1	单 位 UNITS	mm
1	初版发行		X. XX ±0.10	比 例 SCALE			页 次 SHEET	3/4
序号 No.	变更内容 MODIFY CONTENT	日期 MODIFY DATE	X. XXX ±0.10	投 影 Projection	材 料 MATERIAL			
			Angle ±3.0°					

PROFILE OF WAVE SOLDER

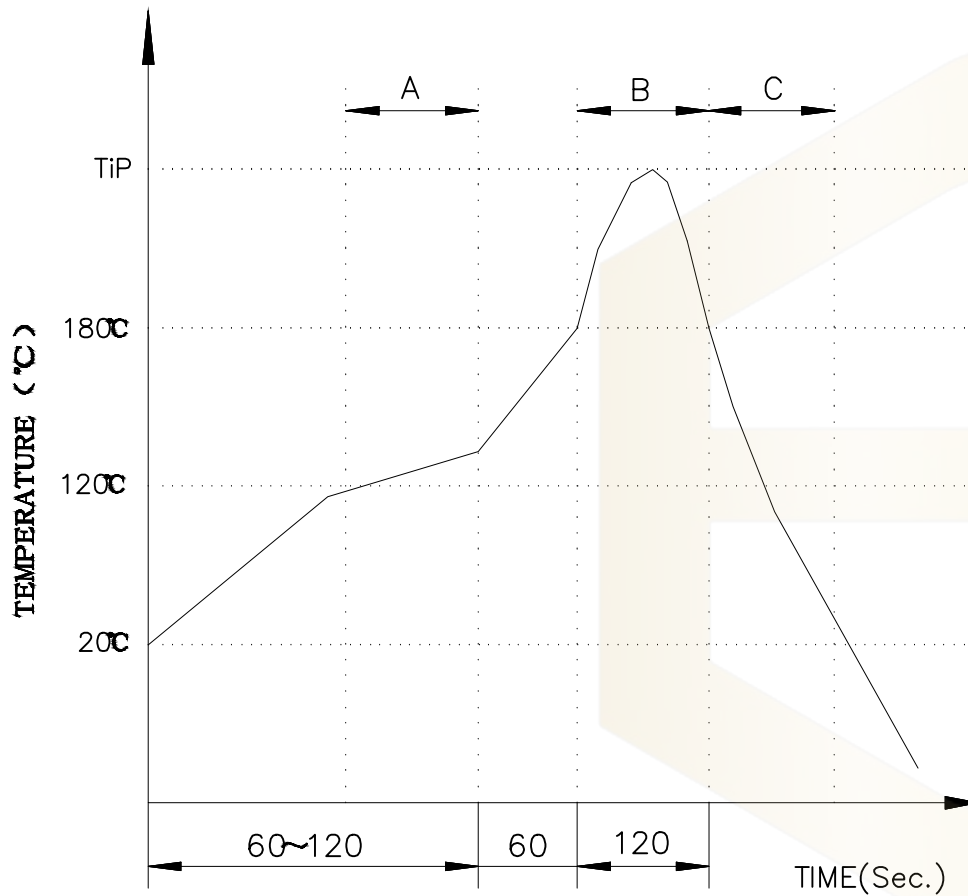

A.Preheating B.Soldering C.Gradual Cooling
 Tip temperature:260±5°C.
 Tip temperature time:5Sec Max.
 Tip melting point of Sn96.5/Ag3/Cu0.5:217°C.

Remarks: after wave soldering, the plastic positioning columns of the product which under the PCB will be slightly melted, but it won't affect its function.

			GENERAL TOLERANCE		制图 DRAWING		 深圳市华灿天禄电子有限公司 ShenzhenhuacantianluELECTRONICS CO.,LTD				
			DIM	TOL	审核 CHECK		产品名称 TITLE		网络插座 (插件 2x1 10/100/1000BASE)	版本 REV.	A
			X.X	±0.30	批准 APPROVAL		产品料号 PART NO.		HC-RJ45-21Q-2x1-1-1	单位 UNITS	mm
1			初版发行		比例 SCALE		材料 MATERIAL			页次 SHEET	4/4
序号 No.	变更内容 MODIFY CONTENT	日期 MODIFY DATE	Angle	±3.0°	投影 Projection	