

TOP VIEW

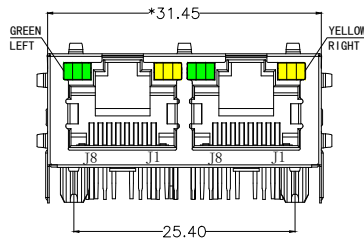

FRONT VIEW

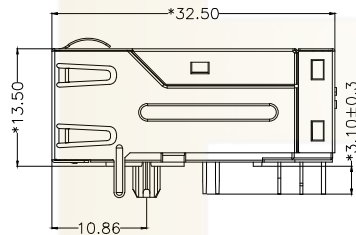

RIGHT SIDE VIEW

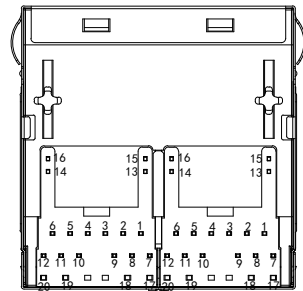

BOTTOM VIEW

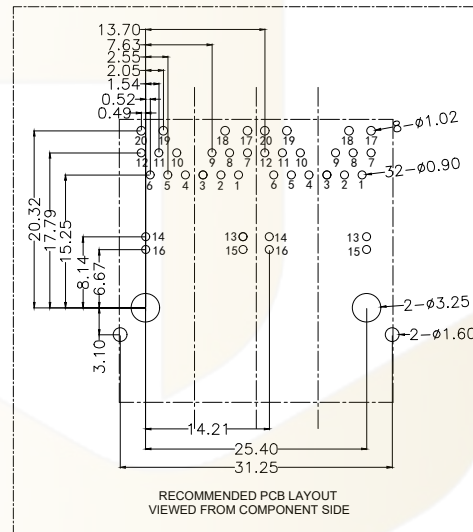

**MATERIAL:**

HOUSING: PA66,UL94V-0,BLACK.  
 TERMINALS BRACKET:PA66,UL94V-0,BLACK.  
 SHIELD: C2680,T=0.20MM,NICKEL PLATING ON ALL AREA.  
 TERMINAL: PHOSPHOR BRONZE C5191,T=0.35MM,  
 6U" GOLD PLATING ON CONTACT AREA.

**MECHANICAL:**

DURABILITY: 750 CYCLES MIN.  
 MATING FORCE: 23N MAX.  
 OPERATING TEMPERATURE: -40°C~+85°C.  
 STORAGE TEMPERATURE: -40°C~+85°C.  
 ALL CRITICAL DIMENSIONS WITH "\*"

**Ordering Information**

HC 61 \* \* \*\* A- M409 - A

Type      LED Color      EMI      Ports      产品序号

01-卧式器件      0-无灯      0-无弹      1-4位      .....

02-立式器件      1-带灯 (左黄右绿)      1-带弹      01-1位      .....

03-卧式器件      2-带灯 (左绿右黄)      2-带弹      02-2位      .....

04-立式器件      3-带灯 (左黄右绿)      3-带弹      25-252位

			GENERAL TOLERANCE	制图 DRAWING	深圳市华灿天禄电子有限公司 ShenzhenhuacantianluELECTRONICS CO.,LTD			
			DIM TOL	审核 CHECK	产品名称 TITLE	网络插座 (卧插 带灯带弹 左绿右黄 TAB-UP 1x2 100BASE POE+)	版本 REV.	A
			X.X ±0.30	批准 APPROVAL	产品料号 PART NO.	HC612702A-M409-A	单位 UNITS	mm
			X.XX ±0.20	比例 SCALE	材料 MATERIAL		页次 SHEET	1/4
			X.XXX ±0.10	投影 Projection				
序号 No.	变更内容 MODIFY CONTENT	日期 MODIFY DATE	Angle ±3.0°					

Suggested Panel Opening:

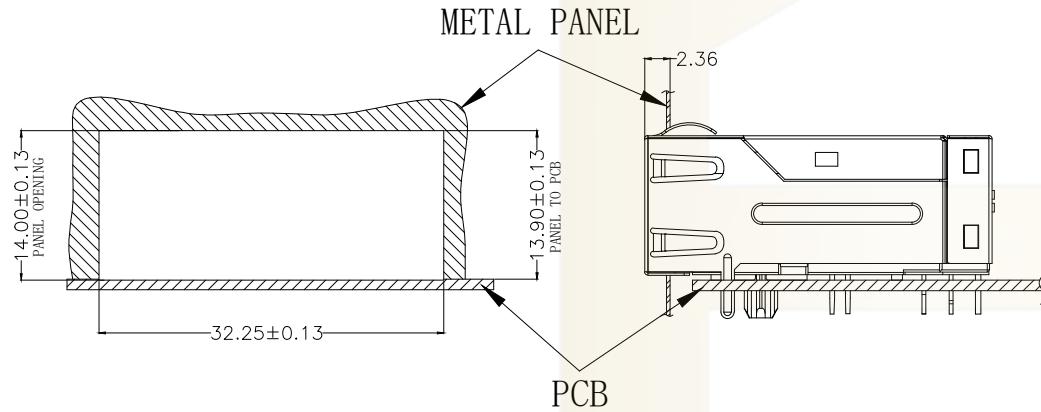

UNIT: mm / inch  
Tolerances:  $\pm 0.10$  / 0.004

Keep-Out Area (Component Side View):

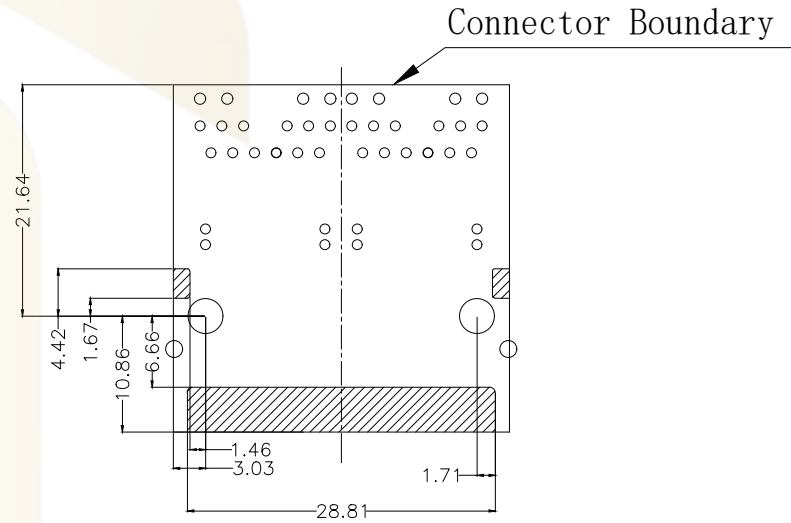

Plug In Side

UNIT: mm / inch  
Tolerances:  $\pm 0.10$  / 0.004

			GENERAL TOLERANCE	制图 DRAWING	深圳市华灿天禄电子有限公司 ShenzhenhuacantianluELECTRONICS CO.,LTD			
			DIM TOL	审核 CHECK	产品名称 TITLE	网络插座 (卧插 带灯带弹 左绿右黄 TAB-UP 1x2 100BASE POE+)	版本 REV.	A
			X.X $\pm 0.30$	批准 APPROVAL	产品料号 PART NO.	HC612702A-M409-A	单位 UNITS	mm
1	初版发行		X.XX $\pm 0.20$	比例 SCALE	材料 MATERIAL		页次 SHEET	2/4
序号 No.	变更内容 MODIFY CONTENT	日期 MODIFY DATE	X.XXX $\pm 0.10$	投影 Projection				
			Angle $\pm 3.0^\circ$					

PCB SIDE TO PHY

CABLE SIDE

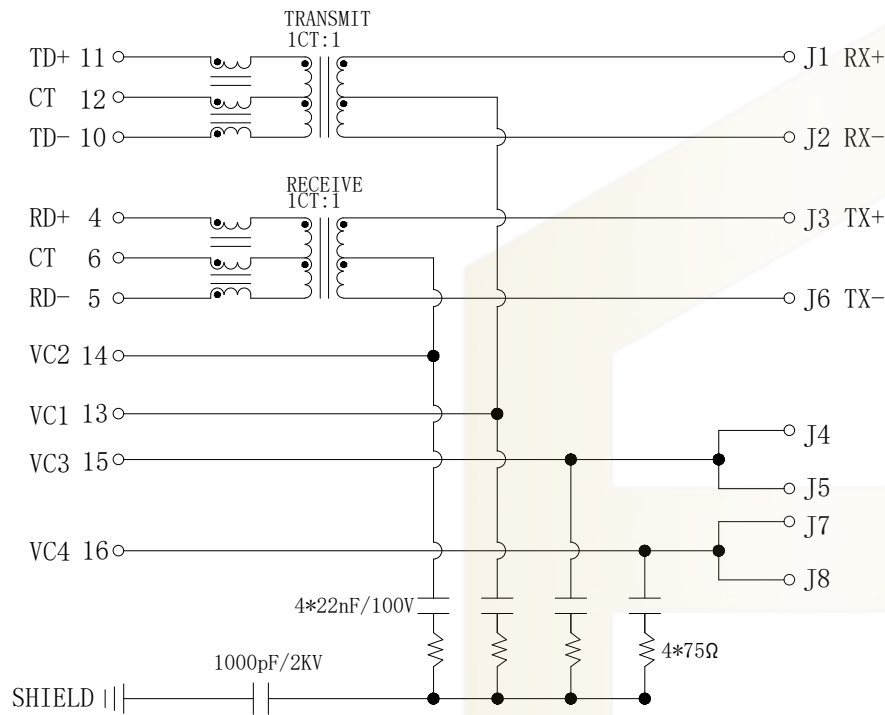

**Electrical:**

1. Turn ratio: 11~10: J1~J2=1CT:1CT(±2%).  
4~5: J3~J6=1CT:1CT(±2%).
2. OCL: 350uH Min. @ 100KHz 100mV RMS (4Channel) 8mA DC BIAS.
3. Insertion Loss: -1.0 dB Max 1~100MHz.
4. Return loss: -20dB Min 1~10MHz;  
-16dB Min 10~30MHz;  
-12dB Min 30~60MHz;  
-10dB Min 60~80MHz.
5. Cross talk: -40dB Min 1~30MHz;  
-35dB Min 30~60MHz;  
-30dB Min 60~100MHz;
6. CMR: -30dB Min 1~100MHz;
7. Hi-Pot: (11.12.10.4.6.5) TO (J1.J2.J3.J6) 500V AC
8. Single port magnetic jack POE magnetics acc. To IEEE802.3at for PSE or PD applications.
9. 100% of production tested to comply with IEEE 802.3 isolation requirements balanced DC line current 720mA max. 57V DC continuous.

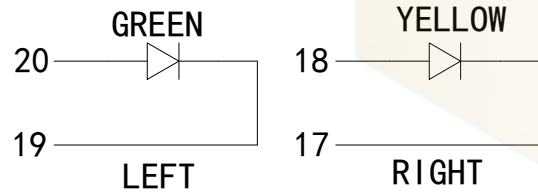

**LED Specification**

Standard LED Color	LED Wavelength	Foward(A)	Foward(V)
Green	565nm	20mA	2.2-2.4V
Yellow	590nm	20mA	2.1-2.5V

			GENREL TOLERANCE	制图 DRAWING	深圳市华灿天禄电子有限公司 ShenzhenhuacantianluELECTRONICS CO.,LTD			
			DIM TOL	审核 CHECK	产品名称 TITLE	网络插座 (卧插 带灯带弹 左绿右黄 TAB-UP 1x2 100BASE POE+)	版本 REV.	A
			X.X ±0.30	批准 APPROVAL	产品料号 PART NO.	HC612702A-M409-A	单位 UNITS	mm
1	初版发行		X.XX ±0.20	比例 SCALE	材料 MATERIAL		页次 SHEET	3/4
序号 No.	变更内容 MODIFY CONTENT	日期 MODIFY DATE	X.XXX ±0.10	投影 Projection				
			Angle ±3.0°					

# PROFILE OF WAVE SOLDER

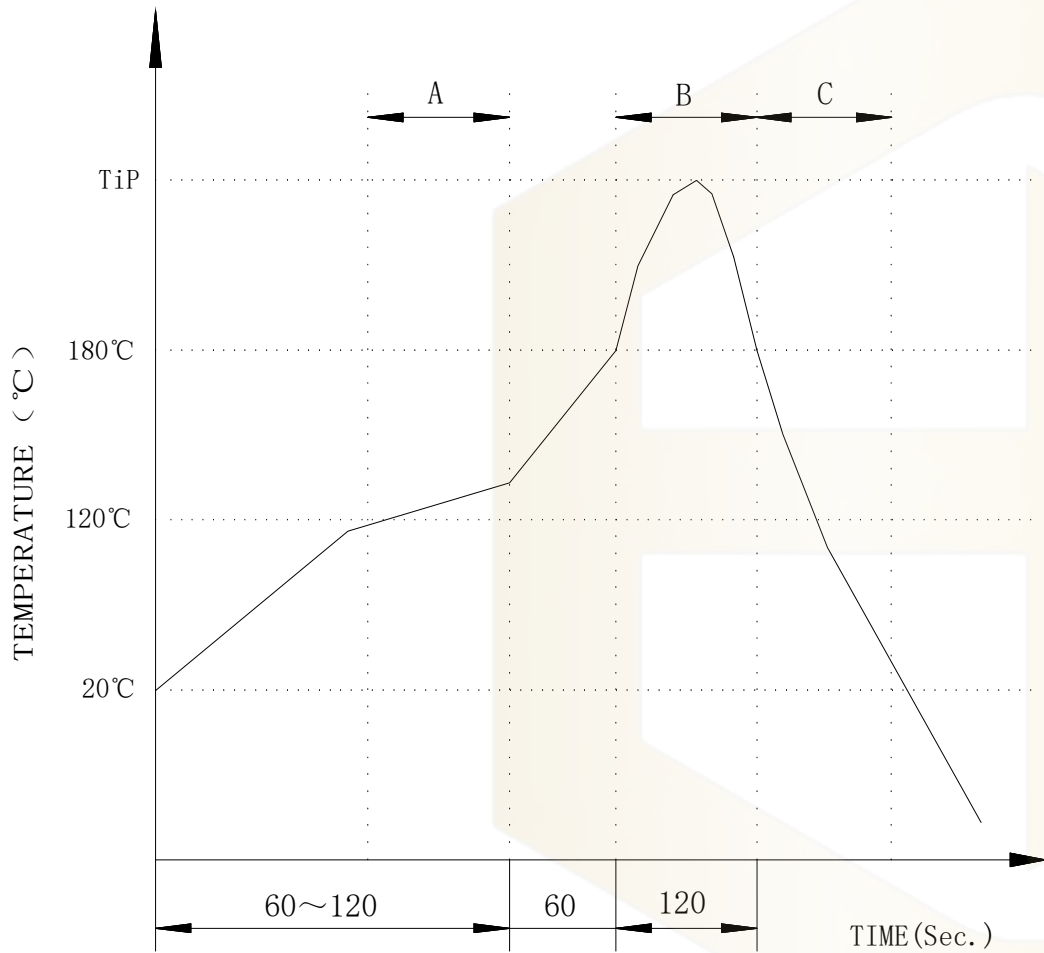

A.Preheating B.Soldering C.Gradual Cooling  
 Tip temperature:260±5°C.  
 Tip temperature time:5Sec Max.  
 Tip melting point of Sn96.5/Ag3/Cu0.5:217°C.

Remarks: after wave soldering, the plastic positioning columns of the product which under the PCB will be slightly melted, but it won't affect its function.

			GENREL TOLERANCE	制图 DRAWING	 深圳市华灿天禄电子有限公司 ShenzhenhuacantianluELECTRONICS CO.,LTD			
			DIM TOL	审核 CHECK	产品名称 TITLE	网络插座 (卧插 带灯带弹 左绿右黄 TAB-UP 1x2 100BASE POE+)	版本 REV.	A
			X. X ±0.30	批准 APPROVAL	产品料号 PART NO.	HC612702A-M409-A	单位 UNITS	mm
1	初版发行		X. XX ±0.20	比例 SCALE	材料 MATERIAL		页次 SHEET	4/4
序号 No.	变更内容 MODIFY CONTENT	日期 MODIFY DATE	X. XXX ±0.10	投影 Projection				
			Angle ±3.0°	