

MATERIAL:
 HOUSING : PBT,UL94V-0,BLACK.
 TERMINALS BRACKET: PBT,UL94V-0,BLACK.
 SHIELD: C2680,T=0.20MM,NICKEL PLATING ON ALL AREA.
 TERMINAL: PHOSPHOR BRONZE C5210,T=0.35MM,
 6U" GOLD PLATING ON CONTACT AREA.

MECHANICAL:
 DURABILITY : 750 CYCLES MIN.
 MATING FORCE : 23N MAX.
 OPERATING TEMPERATURE: -40°C~+85°C.
 STORAGE TEMPERATURE: -40°C~+85°C.
 ALL CRITICAL DIMENSIONS WITH "*"

Ordering Information

HC 6* * * ** A - M*** - A

Type	LED Color	EMI	Ports	产品序号
☐ 卧式插接件	☑ 右黄	☑ 无屏蔽	☑ 1x10	
☐ 立式插接件	☑ 右黄 (左黄可选)	☑ 有屏蔽	☐ 1x10	
☐ 立式插接件	☑ 右黄 (左黄可选)	☑ 有屏蔽	☑ 1x10	
☐ 立式插接件	☑ 右黄 (左黄可选)	☑ 有屏蔽	☑ 1x10	
☐ 立式插接件	☑ 右黄 (左黄可选)	☑ 有屏蔽	☑ 1x10	
☐ 立式插接件	☑ 右黄 (左黄可选)	☑ 有屏蔽	☑ 1x10	
☐ 立式插接件	☑ 右黄 (左黄可选)	☑ 有屏蔽	☑ 1x10	
☐ 立式插接件	☑ 右黄 (左黄可选)	☑ 有屏蔽	☑ 1x10	
☐ 立式插接件	☑ 右黄 (左黄可选)	☑ 有屏蔽	☑ 1x10	
☐ 立式插接件	☑ 右黄 (左黄可选)	☑ 有屏蔽	☑ 1x10	

			GENERAL TOLERANCE		制图		深圳市华灿天禄电子有限公司			
			DIM TOL		DRAWING		ShenzhenhuacantianluELECTRONICS CO.,LTD			
			X.X	±0.30	审核		产品名称	网络插座 (卧插 带灯带弹 左绿 右黄 TAB-DOWN 1x1 10/100BASE)	版本	A
			X.XX	±0.20	检查		TITLE		REV.	
			X.XXX	±0.10	批准		产品料号	HC612701A-M993-A	单位	mm
序号	变更内容	日期	Angle	±3.0°	投影		PART NO.		页次	1/4
No.	MODIFY CONTENT	MODIFY DATE			Projection		MATERIAL		SHEET	

RECOMMENDED PANEL CUTOUT (REFERENCE ONLY) :

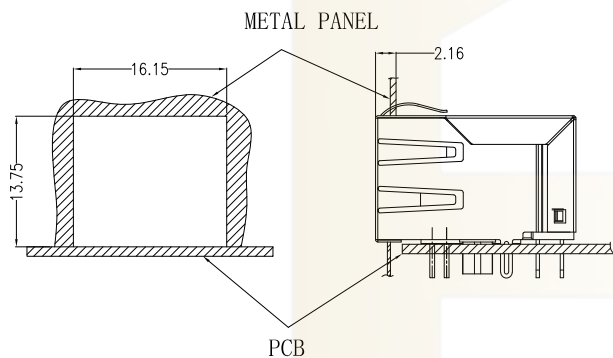

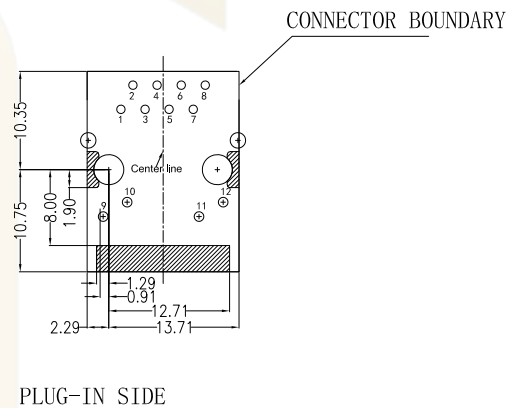

UNIT: MM / INCH
TOLERANCES: $\pm 0.10 / 0.004$
REFERENCE ONLY

KEEP-OUT AREA (COMPONENT SIDE VIEW) :



UNIT: MM / INCH
TOLERANCES: $\pm 0.10 / 0.004$

			GENEAL TOLERANCE	制图 DRAWING	 深圳市华灿天禄电子有限公司 ShenzhenhuacantianluELECTRONICS CO.,LTD				
			DIM TOL	审核 CHECK					
			X.X ± 0.30	批准 APPROVAL		产品名称 TITLE	网络插座 (卧插 带灯带弹 左绿 右黄 TAB-DOWN 1x1 10/100BASE)	版本 REV.	A
1	初版发行		X.XX ± 0.20	比例 SCALE		产品料号 PART NO.	HC612701A-M993-A	单位 UNITS	mm
序号 No.	变更内容 MODIFY CONTENT	日期 MODIFY DATE	X.XXX ± 0.10	投影 Projection		材料 MATERIAL		页次 SHEET	2/4
			Angle $\pm 3.0^\circ$						

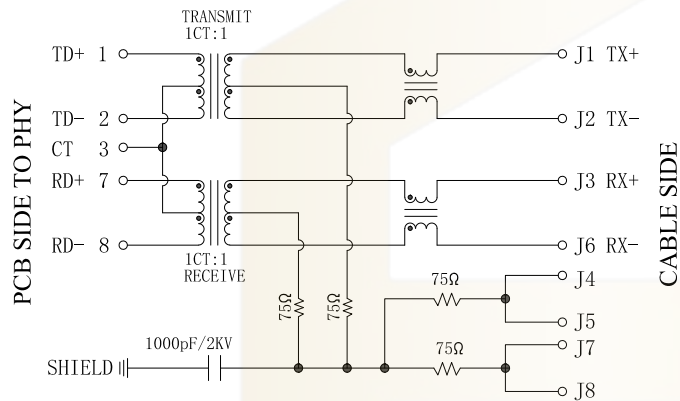

Electrical:

1. Turn ratio: 1~2: J1~J2=1CT:1CT(±2%).
7~8: J3~J6=1CT:1CT(±2%).
2. OCL: 350uH Min. at 100KHz 100mV 8mA DC.
3. Insertion Loss: -1.0 dB Max 1~100MHz.
4. Return loss: -20dB Min 1~10MHz;
-16dB Min 10~30MHz.
-12dB Min 30~60MHz.
-10dB Min 60~80MHz.
5. Cross talk: -40dB Min 1~30MHz;
-35dB Min 30~60MHz;
-30dB Min 60~100MHz;
6. CMR: -30dB Min 1~100MHz;
7. Hi-Pot: 1500V AC & 2250V DC
6S 1mA PRI TO SEC

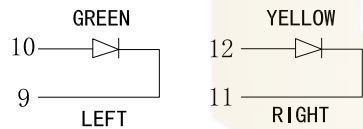

LED Specification

Standard LED Color	LED Wavelength	Foward(A)	Foward(V)
Green	568nm	20mA	1.85-2.45V
Yellow	585nm	20mA	1.7-2.2V

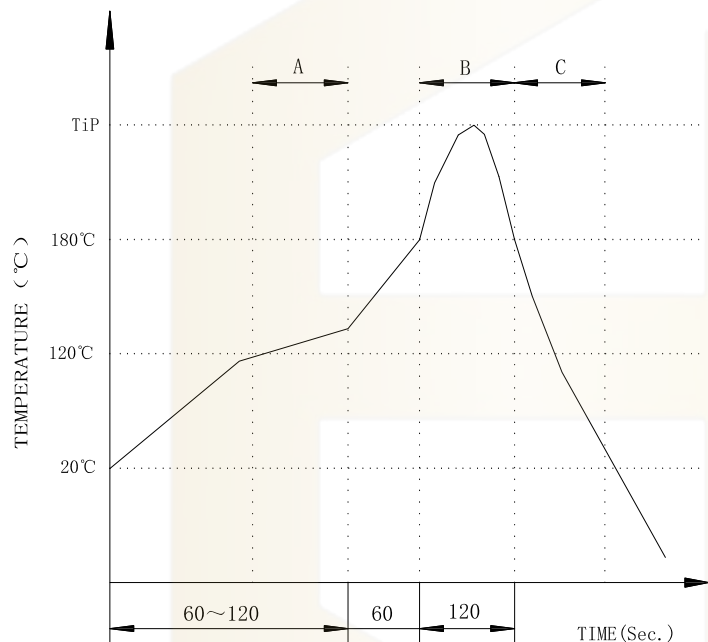

			GENEAL TOLERANCE	制图 DRAWING	深圳市华灿天禄电子有限公司 ShenzhenhuacantianluELECTRONICS CO., LTD				
			DIM TOL	审核 CHECK					
			X.X ±0.30	批准 APPROVAL		产品名称 TITLE	网络插座 (卧插 带灯带弹 左绿 右黄 TAB-DOWN 1x1 10/100BASE)	版本 REV.	A
1	初版发行		X.XX ±0.20	比例 SCALE		产品料号 PART NO.	HC612701A-M993-A	单位 UNITS	mm
序号 No.	变更内容 MODIFY CONTENT	日期 MODIFY DATE	X.XXX ±0.10	投影 Projection		材料 MATERIAL		页次 SHEET	3/4
			Angle ±3.0°						

PROFILE OF WAVE SOLDER



A.Preheating B.Soldering C.Gradual Cooling
 Tip temperature:260±5°C.
 Tip temperature time:5Sec Max.
 Tip melting point of Sn96.5/Ag3/Cu0.5:217°C.

Remarks: after wave soldering, the plastic positioning columns of the product which under the PCB will be slightly melted, but it won't affect its function.

			GENERAL TOLERANCE	制图 DRAWING	 深圳市华灿天禄电子有限公司 ShenzhenhuacantianluELECTRONICS CO.,LTD			
			DIM TOL	审核 CHECK				
			X.X ±0.30	批准 APPROVAL	产品名称 TITLE	网络插座 (卧插 带灯带弹 左绿 右黄 TAB-DOWN 1x1 10/100BASE)	版本 REV.	A
			X.XX ±0.20	比例 SCALE	产品料号 PART NO.	HC612701A-M993-A	单位 UNITS	mm
			X.XXX ±0.10	投影 Projection	材料 MATERIAL			
序号 No.	变更内容 MODIFY CONTENT	日期 MODIFY DATE	Angle ±3.0°		页次 SHEET			
						4/4		