

**MATERIAL:**  
 HOUSING : PBT,UL94V-0,BLACK.  
 TERMINALS BRACKET: PBT,UL94V-0,BLACK.  
 SHIELD: C2680,T=0.20MM,NICKEL PLATING ON ALL AREA.  
 TERMINAL: PHOSPHOR BRONZE C5210,T=0.35MM,  
 6U" GOLD PLATING ON CONTACT AREA.

**MECHANICAL:**  
 DURABILITY : 750 CYCLES MIN.  
 MATING FORCE : 23N MAX.  
 OPERATING TEMPERATURE: -40°C~+85°C.  
 STORAGE TEMPERATURE: -40°C~+85°C.  
 ALL CRITICAL DIMENSIONS WITH "\*"

**Ordering Information**

HC 61 \* \* \*\* A- M305 - A

Type	LED Color	EMI	Ports	产品序号
□ 带灯 (带灯)	□ 绿 (绿)	□ 无 (无)	□ 1-10口	
□ 不带灯 (不带灯)	□ 红 (红)	□ 有 (有)	□ 1-12口	
□ 贴片 (贴片)	□ 蓝 (蓝)	□ 有 (有)	□ 1-8口	
□ 贴片 (贴片)	□ 白 (白)	□ 有 (有)	□ 2-12口	
			□ 2-8口	

		GENERAL TOLERANCE		制图	深圳市华灿天禄电子有限公司 ShenzhenhuacantianluELECTRONICS CO.,LTD			
		DIM	TOL	审核				
		X.X	±0.30	批准	产品名称	网络插座 (插件 带灯无弹)	版本	A
		X.XX	±0.20	CHECK	TITLE	TAB-DOWN 1X1 100BASE)	REV.	
		X.XXX	±0.10	APPROVAL	比例	HC612601A-M305-A	UNIT	mm
序号	变更内容	日期	Angle	±3.0°	PART NO.		UNITS	
No.	MODIFY CONTENT	MODIFY DATE			MATERIAL		SHEET	1/4
				投影				

RECOMMENDED PANEL CUTOUT (REFERENCE ONLY) :

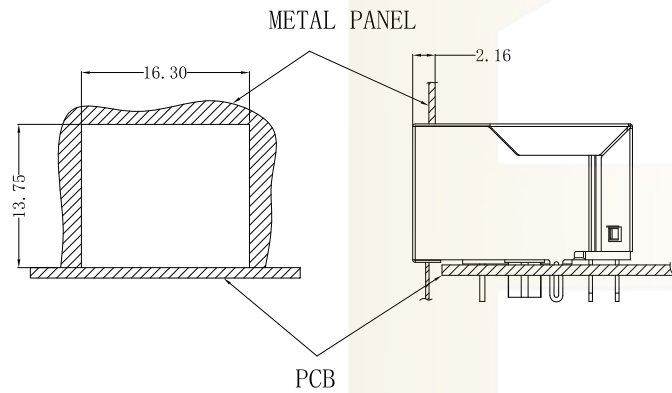

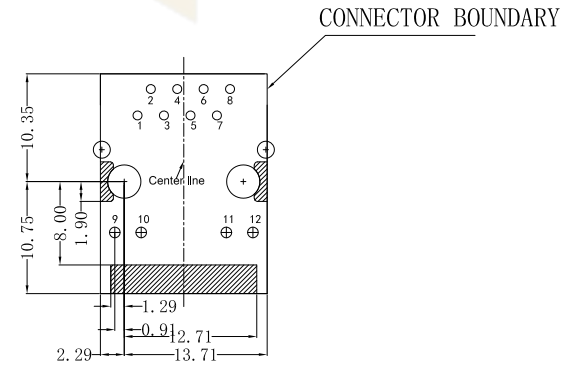

UNIT: MM / INCH  
 TOLERANCES:  $\pm 0.10 / 0.004$   
 REFERENCE ONLY

KEEP-OUT AREA (COMPONENT SIDE VIEW) :



PLUG-IN SIDE

UNIT: MM / INCH  
 TOLERANCES:  $\pm 0.10 / 0.004$

			GENEAL TOLERANCE	制 图 DRAWING	 深圳市华灿天禄电子有限公司 ShenzhenhuacantianluELECTRONICS CO.,LTD			
			DIM TOL	审 核 CHECK				
			X.X $\pm 0.30$	批 准 APPROVAL	产品名称 TITLE	网络插座 (插件 带灯无弹 TAB-DOWN 1X1 100BASE)	版 本 REV.	A
1	初版发行		X.XX $\pm 0.20$	比 例 SCALE	产品料号 PART NO.	HC612601A-M305-A	单 位 UNITS	mm
序号 No.	变更内容 MODIFY CONTENT	日期 MODIFY DATE	X.XXX $\pm 0.10$	投 影 Projection	材 料 MATERIAL		页 次 SHEET	2/4
			Angle $\pm 3.0^\circ$					

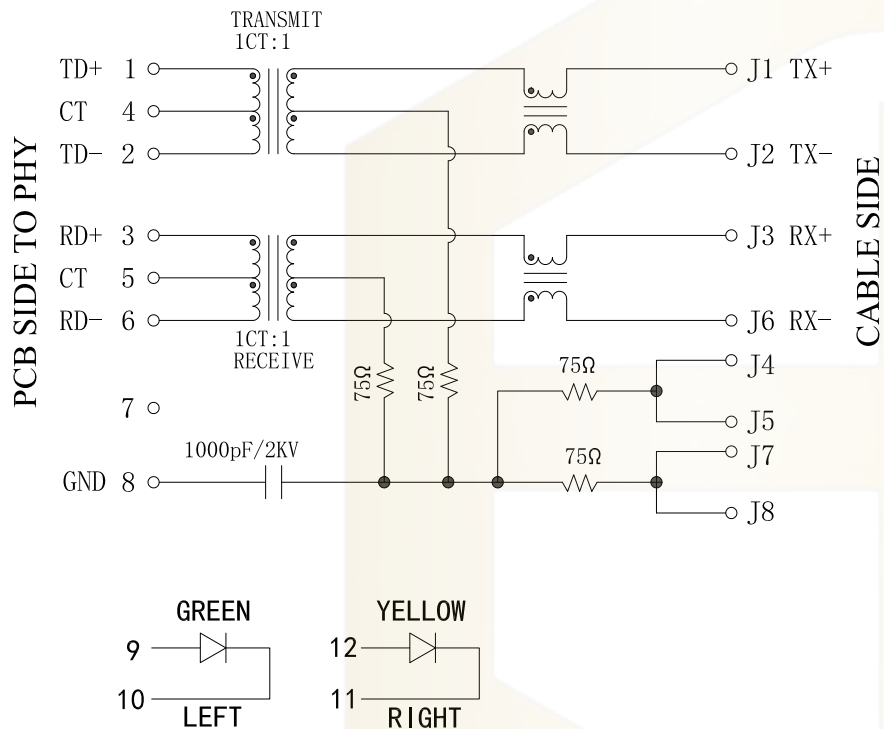

**Electrical:**

- Turn ratio: 1~2: J1~J2=1CT:1CT(±2%).  
3~6: J3~J6=1CT:1CT(±2%).
- OCL: 350uH Min. at 100KHz 100mV 8mA DC.
- Insertion Loss: -1.0 dB Max 1~100MHz.
- Return loss: -20dB Min 1~10MHz;  
-16dB Min 10~30MHz.  
-12dB Min 30~60MHz.  
-10dB Min 60~80MHz.
- Cross talk: -40dB Min 1~30MHz;  
-35dB Min 30~60MHz;  
-30dB Min 60~100MHz;
- CMR: -30dB Min 1~100MHz;
- Hi-Pot: 1500V AC & 2250V DC  
6S 1mA PRI TO SEC

**LED Specification**

Standard LED Color	LED Wavelength	Foward(A)	Foward(V)
Green	568nm	20mA	1.85-2.45V
Yellow	585nm	20mA	1.7-2.2V

			GENEAL TOLERANCE	制图 DRAWING	深圳市华灿天禄电子有限公司 ShenzhenhuacantianluELECTRONICS CO., LTD			
			DIM TOL	审核 CHECK	产品名称 TITLE	网络插座 (插件 带灯无弹 TAB-DOWN 1X1 100BASE)	版本 REV.	A
			X.X ±0.30	批准 APPROVAL	产品料号 PART NO.	HC612601A-M305-A	单位 UNITS	mm
1	初版发行		X.XX ±0.20	比例 SCALE			页次 SHEET	3/4
序号 No.	变更内容 MODIFY CONTENT	日期 MODIFY DATE	X.XXX ±0.10	投影 Projection	材料 MATERIAL			
			Angle ±3.0°					

# PROFILE OF WAVE SOLDER

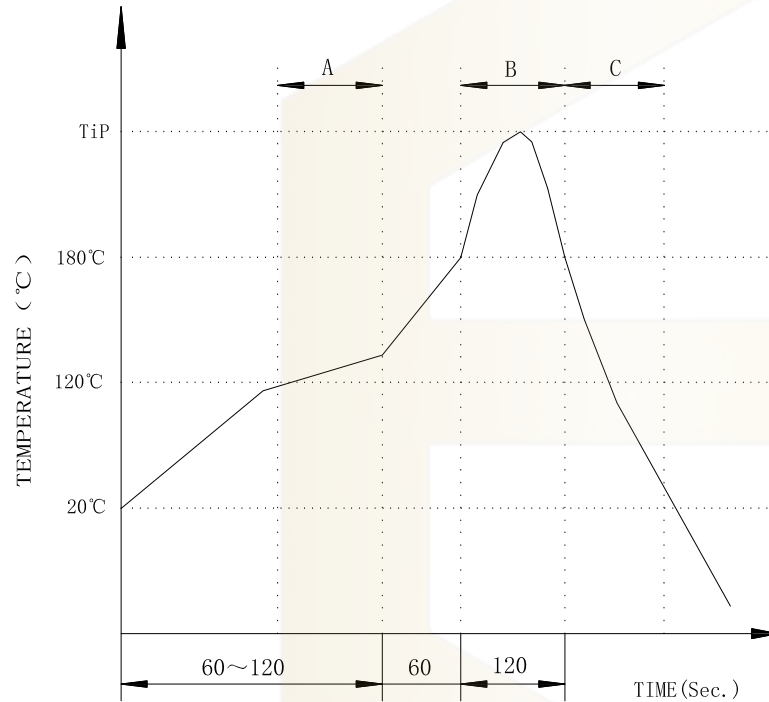

A.Preheating B.Soldering C.Gradual Cooling  
 Tip temperature:260±5°C.  
 Tip temperature time:5Sec Max.  
 Tip melting point of Sn96.5/Ag3/Cu0.5:217°C.

Remarks: after wave soldering, the plastic positioning columns of the product which under the PCB will be slightly melted, but it won't affect its function.

			GENE RL TOLERANCE	制 图 DRAWING	 深圳市华灿天禄电子有限公司 ShenzhenhuacantianluELECTRONICS CO.,LTD			
			DIM TOL	审 核 CHECK				
			X.X ±0.30	批 准 APPROVAL	产品名称 TITLE	网络插座 (插件 带灯无弹 TAB-DOWN 1X1 100BASE)	版 本 REV.	A
1	初版发行		X.XX ±0.20	比 例 SCALE	产品料号 PART NO.	HC612601A-M305-A	单 位 UNITS	mm
序号 No.	变更内容 MODIFY CONTENT	日期 MODIFY DATE	X.XXX ±0.10	投 影 Projection	材 料 MATERIAL		页 次 SHEET	4/4
			Angle ±3.0°	