

MATERIAL:

HOUSING: PBT,UL94V-0,BLACK.
 TERMINALS BRACKET: PBT,UL94V-0,BLACK.
 SHIELD: C2680,T=0.20MM,NICKEL PLATING ON ALL AREA.
 TERMINAL: PHOSPHOR BRONZE C5210,T=0.35MM,
 6U" GOLD PLATING ON CONTACT AREA.

MECHANICAL:

DURABILITY: 750 CYCLES MIN.
 MATING FORCE: 23N MAX.
 OPERATING TEMPERATURE: -40°C~+85°C.
 STORAGE TEMPERATURE: -40°C~+85°C.
 ALL CRITICAL DIMENSIONS WITH "*"

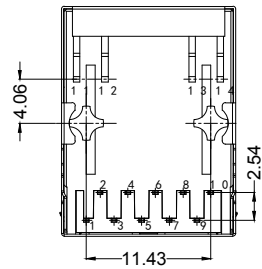
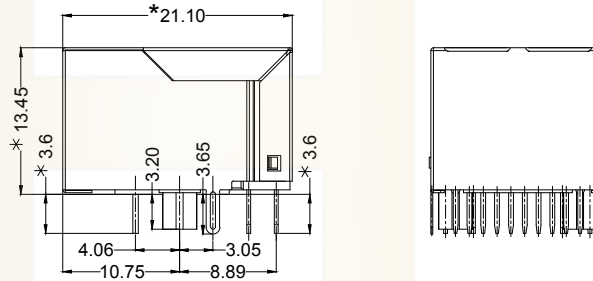
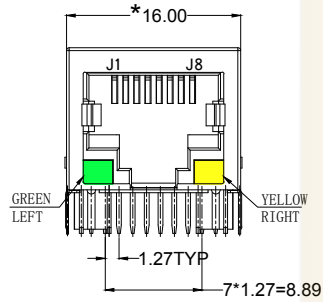
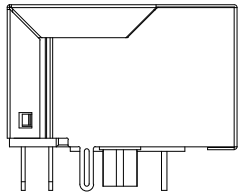

			GENREL TOLERANCE		制 图 DRAWING		深圳市华灿天禄电子有限公司 ShenzhenhuacantianluELECTRONICS CO.,LTD				
			DIM	TOL	审 核 CHECK		产品名称 TITLE		网络插座 (插件 1X1 2.5G 口朝下)	版本 REV.	A
			X.X	±0.30	批 准 APPROVAL		产品料号 PART NO.		HC911130C-M914-A	单 位 UNITS	mm
1			初版发行				投 影 Projection				
序号 No.	变更内容 MODIFY CONTENT	日期 MODIFY DATE	Angle ±3.0°				材 料 MATERIAL		页 次 SHEET		

RECOMMENDED PANEL CUTOUT (REFERENCE ONLY) :

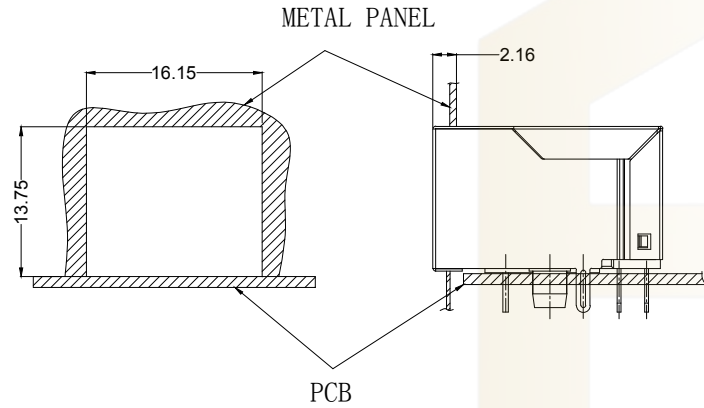

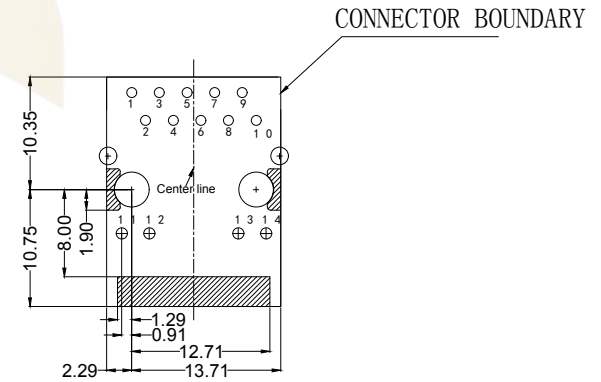

UNIT: MM / INCH
TOLERANCES: ± 0.10 / 0.004
REFERENCE ONLY

KEEP-OUT AREA (COMPONENT SIDE VIEW) :



PLUG-IN SIDE

UNIT: MM / INCH
TOLERANCES: ± 0.10 / 0.004

			GENERAL TOLERANCE		制图 DRAWING		 深圳市华灿天禄电子有限公司 ShenzhenhuacantianluELECTRONICS CO.,LTD				
			DIM	TOL	审核 CHECK		产品名称 TITLE		网络插座 (插件 1X1 2.5G 口朝下)	版本 REV.	A
			X.X	± 0.30	批准 APPROVAL		产品料号 PART NO.		HC911130C-M914-A	单位 UNITS	mm
1			初版发行		比例 SCALE		材料 MATERIAL			页次 SHEET	2/4
序号 No.	变更内容 MODIFY CONTENT	日期 MODIFY DATE	Angle	$\pm 3.0^\circ$	投影 Projection						

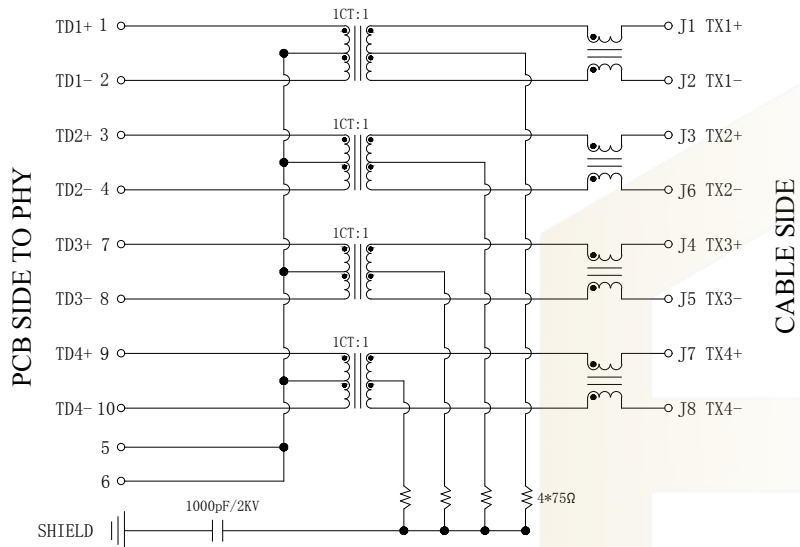



Electrical:

1. Turn ratio: 1~2: J1~J2=1CT:1CT(±2%).
3~4: J3~J6=1CT:1CT(±2%).
7~8: J4~J5=1CT:1CT(±2%).
9~10: J7~J8=1CT:1CT(±2%).
2. OCL: 180uH Min. @ 100KHz 0.1V.
3. Insertion Loss: -1.0 dB Max 1~125MHz.
4. Return loss: -20dB Min 1 ~ 40MHz;
-20+15LOG₁₀(f/40MHz) Min 40~200MHz.
5. Cross talk: -30dB Min 1~125MHz.
6. CMR: -30dB Min 30~200MHz;
7. Hi-Pot: 2250V DC 6S 1mA PRI TO SEC

LED Specification

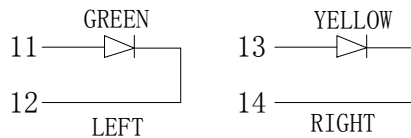
Standard LED Color	LED Wavelength	Foward(A)	Foward(V)
Green	568nm	20mA	1.85-2.45V
Yellow	585nm	20mA	1.7-2.2V



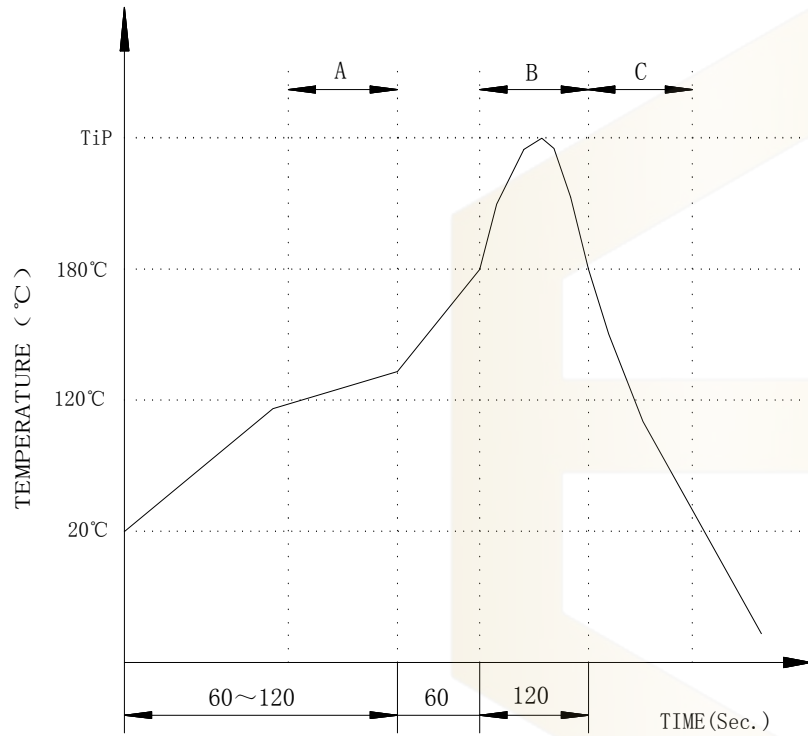

			GENERAL TOLERANCE		制 图 DRAWING		 深圳市华灿天禄电子有限公司 ShenzhenhuacantianluELECTRONICS CO., LTD				
			DIM	TOL	审 核 CHECK						
			X. X	±0.30	批 准 APPROVAL		产品名称 TITLE	网络插座 (插件 1X1 2.5G 口朝下)	版本 REV.	A	
1			初版发行		X. XX		±0.20	产品料号 PART NO.	HC911130C-M914-A	单 位 UNITS	mm
序号 No.	变更内容 MODIFY CONTENT	日期 MODIFY DATE	Angle		±3.0°	投 影 Projection		材 料 MATERIAL		页 次 SHEET	3/4

PROFILE OF WAVE SOLDER



A.Preheating B.Soldering C.Gradual Cooling
 Tip temperature:260±5°C.
 Tip temperature time:5Sec Max.
 Tip melting point of Sn96.5/Ag3/Cu0.5:217°C.

Remarks: after wave soldering, the plastic positioning columns of the product which under the PCB will be slightly melted, but it won't affect its function.

			GENERAL TOLERANCE		制图 DRAWING	 深圳市华灿天禄电子有限公司 ShenzhenhuacantianluELECTRONICS CO.,LTD					
			DIM	TOL	审核 CHECK			产品名称 TITLE	网络插座 (插件 1X1 2.5G 口朝下)	版本 REV.	A
			X.X	±0.30	批准 APPROVAL			产品料号 PART NO.	HC911130C-M914-A	单位 UNITS	mm
			X.XX	±0.20	比例 SCALE			材料 MATERIAL		页次 SHEET	4/4
			X.XXX	±0.10	投影 Projection						
序号 No.	变更内容 MODIFY CONTENT	日期 MODIFY DATE	Angle	±3.0°							