

MATERIAL:

HOUSING: LCP,UL94V-0,BLACK.
 TERMINALS BRACKET:PA46,UL94V-0,BLACK.
 SHIELD: C2680,T=0.20MM,NICKEL PLATING ON ALL AREA.
 TERMINAL: PHOSPHOR BRONZE C5210,T=0.35MM,
 6U" GOLD PLATING ON CONTACT AREA.

MECHANICAL:

DURABILITY: 750 CYCLES MIN.
 MATING FORCE: 23N MAX.
 OPERATING TEMPERATURE: -40°C~+85°C.
 STORAGE TEMPERATURE:-40°C~+85°C.
 ALL CRITICAL DIMENSIONS WITH "*"

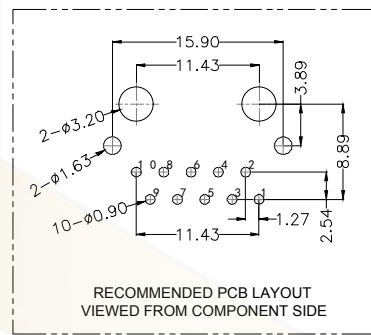

RECOMMENDED PCB LAYOUT
 VIEWED FROM COMPONENT SIDE

Ordering Information

HC 6* * * ** A - M*** - A

Type	LED Color	EMI	Ports	产品序号
61-立式插件	0-无灯	0-无弹	1-8口	
62-立式插件	1-带灯 (左黄右绿)	1-带弹	01-1口	
63-卧式贴片	2-带灯 (左黄右绿)	2-带弹	02-2口	
64-立式贴片	3-带灯 (左黄右绿)	3-带弹	03-2口	
65-立式贴片	4-带灯 (左绿右黄)	4-带弹	04-2口	
66-立式贴片	5-带灯 (左绿右黄, 绿-黄)	5-带弹	05-2口	
67-立式贴片	6-带灯 (左绿, 右黄)	6-带弹	06-2口	

			GENRL TOLERANCE	制图 DRAWING	深圳市华灿天禄电子有限公司 ShenzhenhuacantianluELECTRONICS CO.,LTD			
			DIM TOL	审核 CHECK				
			X.X ±0.30	批准 APPROVAL	产品名称 TITLE	网络插座 (立插 无灯无弹 过回流焊 TAB-UP 1x1 1000BASE)	版本 REV.	A
			X.XX ±0.20	比例 SCALE	产品料号 PART NO.	HC620601A-M958-A	单位 UNITS	mm
			X.XXX ±0.10	投影 Projection	材料 MATERIAL		页次 SHEET	1/4
序号 No.	变更内容 MODIFY CONTENT	日期 MODIFY DATE	Angle ±3.0°					

Suggested Panel Opening:

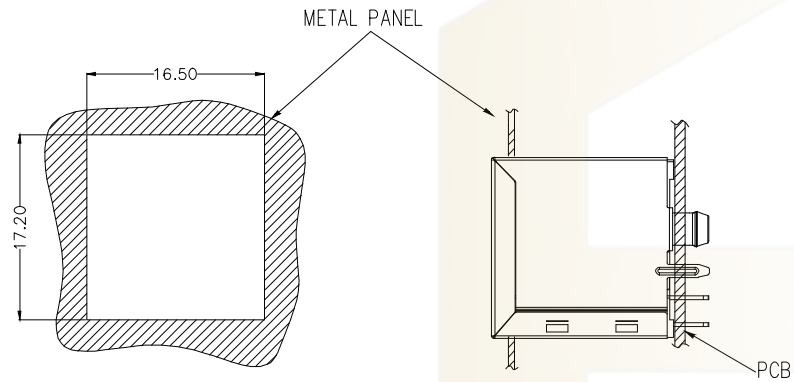

UNIT: mm / inch
Tolerances: ± 0.10 / 0.004

Keep-Out Area (Component Side View):

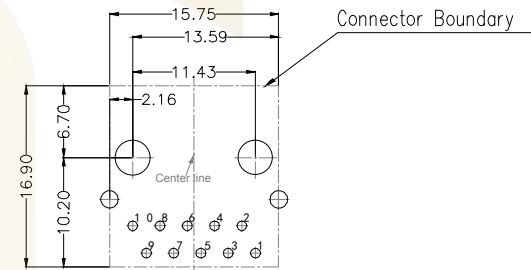

UNIT: mm / inch
Tolerances: ± 0.10 / 0.004

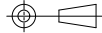
			GENEAL TOLERANCE	制图 DRAWING	 深圳市华灿天禄电子有限公司 ShenzhenhuacantianluELECTRONICS CO., LTD			
			DIM TOL	审核 CHECK				
			X.X ± 0.30	批准 APPROVAL	产品名称 TITLE	网络插座 (立插 无灯无弹 过回流焊 TAB-UP 1x1 1000BASE)	版本 REV.	A
1	初版发行		X.XX ± 0.20	比例 SCALE	产品料号 PART NO.	HC620601A-M958-A	单位 UNITS	mm
序号 No.	变更内容 MODIFY CONTENT	日期 MODIFY DATE	X.XXX ± 0.10	投影 Projection	材料 MATERIAL		页次 SHEET	2/4
			Angle $\pm 3.0^\circ$					

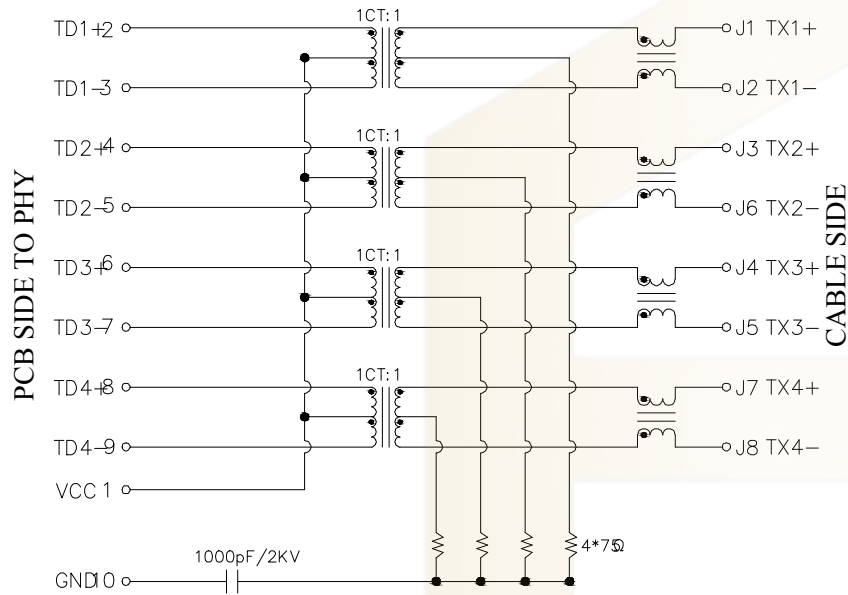

Electrical:

- Turn ratio: 2~3: J1~J2=1CT:1CT(±2%).
4~5: J3~J6=1CT:1CT(±2%).
6~7: J4~J5=1CT:1CT(±2%).
8~9: J7~J8=1CT:1CT(±2%).
- OCL: 350uH Min.at 100KHz 100mV 8mA DC.
- Insertion Loss: -1.0 dB Max 1~100MHz.
- Return loss: -18dB Min 1~30MHz;
-14dB Min 30~60MHz.
-12dB Min 60~80MHz.
-10dB Min 80~100MHz.
- Cross talk: -40dB Min 1~30MHz;
-35dB Min 30~60MHz;
-30dB Min 60~100MHz;
- CMR: -30dB Min 1~100MHz;
- Hi-Pot: 2250V DC 6S 1mA PRI TO SEC

			GENEAL TOLERANCE	制图 DRAWING	深圳市华灿天禄电子有限公司 ShenzhenhuacantianluELECTRONICS CO.,LTD			
			DIM TOL	审核 CHECK	产品名称 TITLE	网络插座 (立插 无灯无弹 过回流焊 TAB-UP 1x1 1000BASE)	版本 REV.	A
			X.X ±0.30	批准 APPROVAL	产品料号 PART NO.	HC620601A-M958-A	单位 UNITS	mm
1	初版发行		X.XX ±0.20	比例 SCALE	材料 MATERIAL		页次 SHEET	3/4
序号 No.	变更内容 MODIFY CONTENT	日期 MODIFY DATE	X.XXX ±0.10	投影 Projection				
			Angle ±3.0°					

PROFILE OF REFLOW SOLDERING

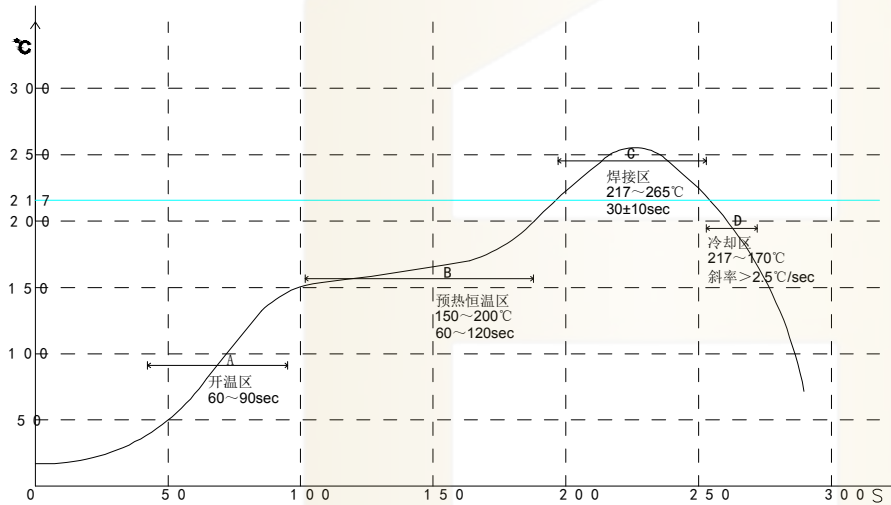

- A. Temperature range of open
 - B. Preheat temperature zone
 - C. The welding zone
 - D. The cooling zone
- Tip temperature: 260±5° C.
Tip temperature time: 3 ±10 Sec.
Tip melting point of Sn96.5/Ag3/Cu0.5.

			GENEAL TOLERANCE	制图 DRAWING	深圳市华灿天禄电子有限公司 ShenzhenhuacantianluELECTRONICS CO.,LTD				
			DIM TOL	审核 CHECK	产品名称 TITLE		网络插座 (立插 无灯无弹 过回流焊 TAB-UP 1x1 1000BASE)	版本 REV.	A
			X.X ±0.30	批准 APPROVAL	产品料号 PART NO.		HC620601A-M958-A	单位 UNITS	mm
1	初版发行		X.XX ±0.20	比例 SCALE	材料 MATERIAL			页次 SHEET	4/4
序号 No.	变更内容 MODIFY CONTENT	日期 MODIFY DATE	X.XXX ±0.10	投影 Projection					
			Angle ±3.0°						