

MATERIAL:

HOUSING: PA66,UL94V-0,BLACK.
 TERMINALS BRACKET: PBT,UL94V-0,BLACK.
 SHIELD: C2680,T=0.20MM,NICKEL PLATING ON ALL AREA.
 TERMINAL: PHOSPHOR BRONZE C5191,T=0.35MM,
 6U" GOLD PLATING ON CONTACT AREA.

MECHANICAL:

DURABILITY: 750 CYCLES MIN.
 MATING FORCE: 23N MAX.
 OPERATING TEMPERATURE: -40°C~+85°C.
 STORAGE TEMPERATURE: -40°C~+85°C.
 ALL CRITICAL DIMENSIONS WITH "*"

Ordering Information

HC 6* * * ** A - M*** - A

Type	LED Color	EMI	Ports	产品序号
61-卧式插件	0-无灯	0-无弹	0-无灯	
62-立式插件	1-带灯 (左黄右绿)	1-带弹	01-113	
63-卧式贴片	2-带灯 (左绿右黄)	2-带弹	02-213	
64-立式贴片	3-带灯 (左黄右绿)	3-带弹	Shielding	
65-立式贴片	4-带灯 (左绿右黄)	4-带弹	22-02213	
	5-带灯 (左绿右黄, 绿-黄)	5-带弹	(无弹版)	
	6-带灯 (左绿, 右黄-黄)	6-带弹	
	7-带灯 (左绿-橙, 右黄)	7-带弹		

			GENEAL TOLERANCE	制图 DRAWING	深圳市华灿天禄电子有限公司 ShenzhenhuacantianluELECTRONICS CO.,LTD			
			DIM TOL	审核 CHECK	产品名称 TITLE	网络插座 (卧插 无灯无弹 TAB-DOWN 2x1 100BASE)	版本 REV.	A
			X.X ±0.30	批准 APPROVAL	产品料号 PART NO.	HC610621A-M966-A	单位 UNITS	mm
1	初版发行		X.XX ±0.20	比例 SCALE	材料 MATERIAL		页次 SHEET	1/4
序号 No.	变更内容 MODIFY CONTENT	日期 MODIFY DATE	X.XXX ±0.10	投影 Projection				
			Angle ±3.0°					

SUGGESTED PANEL OPENING:

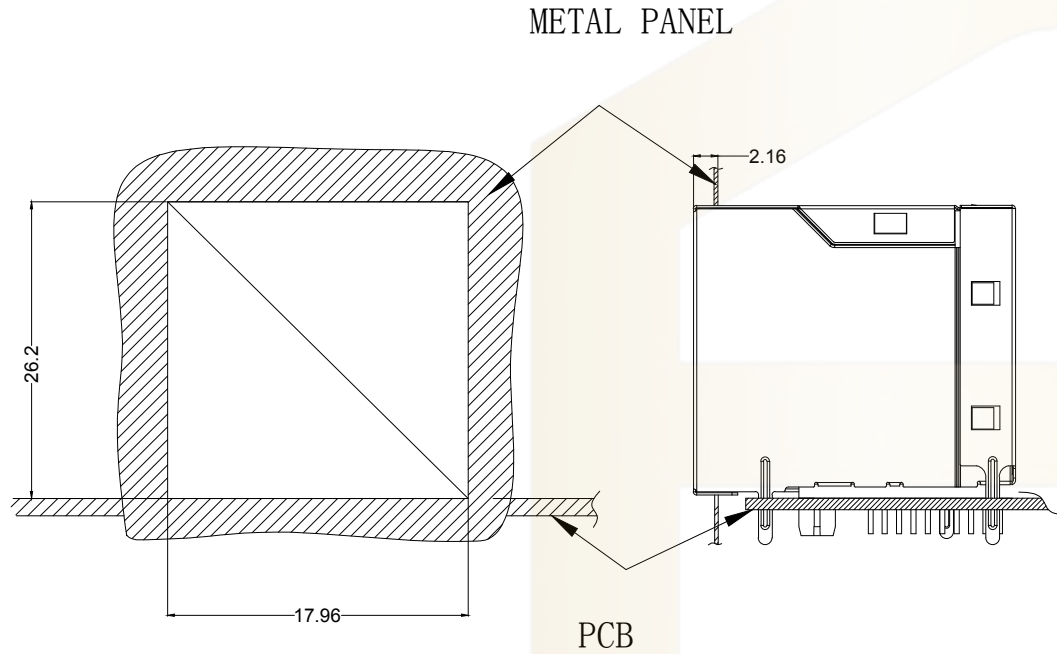

UNIT: MM / INCH
TOLERANCES: ± 0.10 / 0.004

KEEP-OUT AREA (COMPONENT SIDE VIEW):

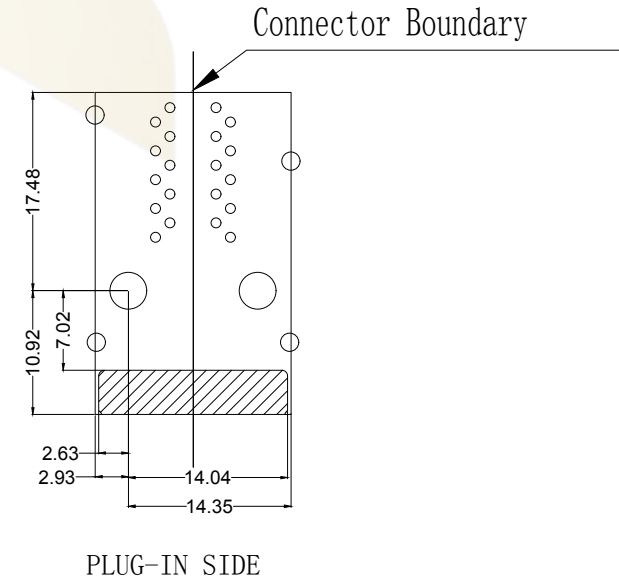

UNIT: MM / INCH
TOLERANCES: ± 0.10 / 0.004

			GENEAL TOLERANCE	制图 DRAWING	深圳市华灿天禄电子有限公司 ShenzhenhuacantianluELECTRONICS CO.,LTD			
			DIM TOL	审核 CHECK	产品名称 TITLE	网络插座 (卧插 无灯无弹 TAB-DOWN 2x1 100BASE)	版本 REV.	A
			X.X ± 0.30	批准 APPROVAL	产品料号 PART NO.	HC610621A-M966-A	单位 UNITS	mm
1	初版发行		X.XX ± 0.20	比例 SCALE	材料 MATERIAL		页次 SHEET	2/4
序号 No.	变更内容 MODIFY CONTENT	日期 MODIFY DATE	X.XXX ± 0.10	投影 Projection				
			Angle $\pm 3.0^\circ$					

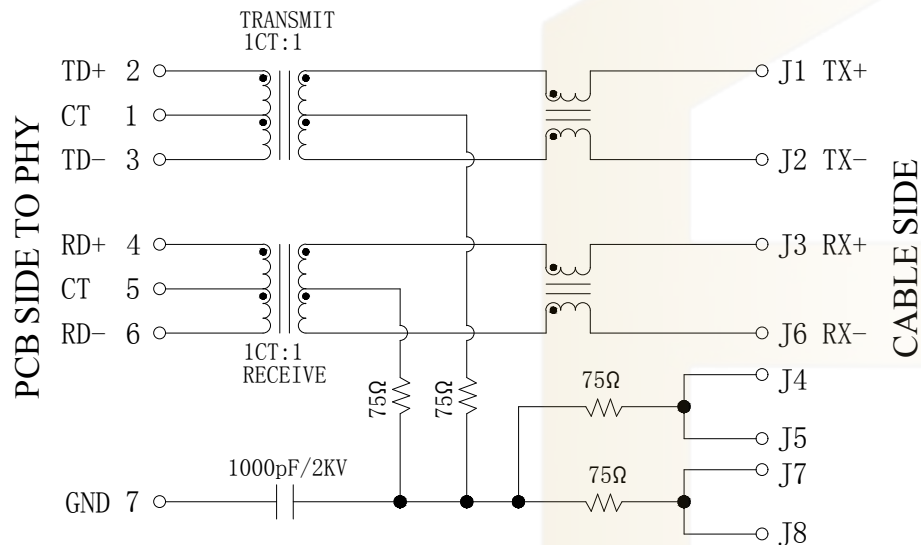

Electrical:

1. Turn ratio: 2~3: J1~J2=1CT:1CT(±2%).
4~6: J3~J6=1CT:1CT(±2%).
2. OCL: 350uH Min. at 100KHz 100mV 8mA DC.
3. Insertion Loss: -1.2 dB Max 1~100MHz.
4. Return loss: -16dB Min 1~30MHz;
-12dB Min 30~60MHz;
-10dB Min 60~80MHz.
5. Cross talk: -30dB Min 1~100MHz;
6. CMR: -30dB Min 1~100MHz;
7. Hi-Pot: 1500V AC & 2250V DC
6S 1mA PRI TO SEC

			GENEAL TOLERANCE	制图 DRAWING	深圳市华灿天禄电子有限公司 ShenzhenhuacantianluELECTRONICS CO., LTD				
			DIM TOL	审核 CHECK	产品名称 TITLE		网络插座 (卧插 无灯无弹 TAB-DOWN 2x1 100BASE)	版本 REV.	A
			X.X ±0.30	批准 APPROVAL	产品料号 PART NO.		HC610621A-M966-A	单位 UNITS	mm
1	初版发行		X.XX ±0.20	比例 SCALE	材料 MATERIAL			页次 SHEET	3/4
序号 No.	变更内容 MODIFY CONTENT	日期 MODIFY DATE	X.XXX ±0.10	投影 Projection					
			Angle ±3.0°						

PROFILE OF WAVE SOLDER

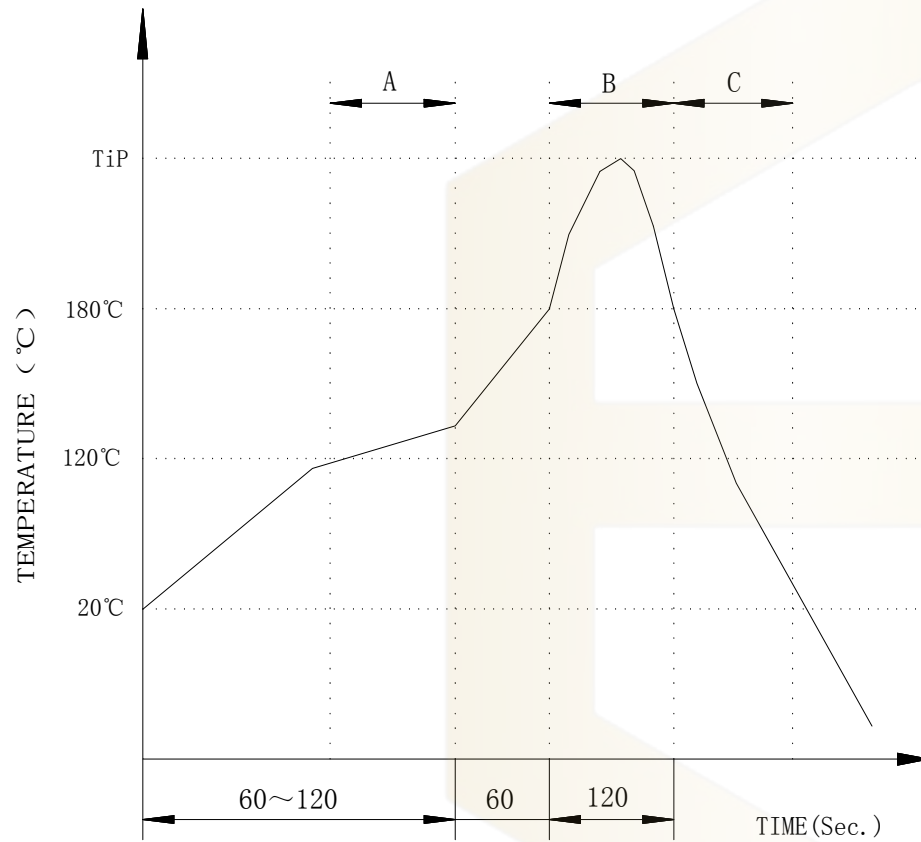

A. Preheating B. Soldering C. Gradual Cooling
 Tip temperature: $260 \pm 5^\circ \text{C}$.
 Tip temperature time: 5Sec Max.
 Tip melting point of Sn96.5/Ag3/Cu0.5: 217°C .

Remarks: after wave soldering, the plastic positioning columns of the product which under the PCB will be slightly melted, but it won't affect its function.

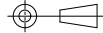
			GENEAL TOLERANCE	制图 DRAWING	 深圳市华灿天禄电子有限公司 ShenzhenhuacantianluELECTRONICS CO.,LTD					
			DIM TOL	审核 CHECK			产品名称 TITLE	网络插座 (卧插 无灯无弹 TAB-DOWN 2x1 100BASE)	版本 REV.	A
			X.X ±0.30	批准 APPROVAL			产品料号 PART NO.	HC610621A-M966-A	单位 UNITS	mm
1	初版发行		X.XX ±0.20	比例 SCALE			材料 MATERIAL		页次 SHEET	4/4
序号 No.	变更内容 MODIFY CONTENT	日期 MODIFY DATE	X.XXX ±0.10	投影 Projection						
			Angle ±3.0°							