

NOTES:  
 1. MATERIAL: SEE "TABLE 1";  
 2. FINISH: SEE "TABLE 1";  
 3. ELECTRICAL :  
 3-1.CONTACT CURRENT RATING :  
 5A(VBUS PIN 1.5A/PIN),  
 5A(GND PIN 1.25A/PIN MAX),0.25A/PIN(OTHER PIN).  
 3-2.INSULATION RESISTANCE :  
 100 MEGAOHMS MIN. AT 250VDC.  
 3-3.DIELECTRIC WITHSTANDING VOLTAGE :  
 100VAC MIN.  
 3-4.LOW LEVEL CONTACT RESISTANCE :  
 INITIAL 40mΩ MAX.  
 AFTER 50mΩ MAX.  
 4.MECHANICAL CHARACTERISTICS :  
 4-1. MATING FORCE: 5~20N.  
 4-2. UNMATING FORCE: 8~20N(INITIAL),6~20N(AFTER 10000 CYCLES);  
 4-3.DURABILITY : 10,000 MATING CYCLES.  
 4-4.OPERATING TEMPERATURE :-40°C TO +80°C

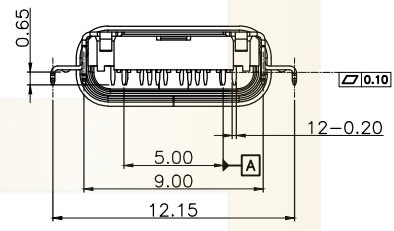

USB TYPE-C PIN ASSIGNMENTS			
PIN NUMBER	SIGNAL NAME	PIN NUMBER	SIGNAL NAME
A1	GND	B12	GND
A2	SSTXP1	B11	SSRXP1
A3	SSTXN1	B10	SSRXN1
A4	VBUS	B9	VBUS
A5	CC1	B8	SBU2
A6	Dp1	B7	Dn2
A7	Dn1	B6	Dp2
A8	SBU1	B5	CC2
A9	VBUS	B4	VBUS
A10	SSRXN2	B3	SSTXN2
A11	SSRXP2	B2	SSTXP2
A12	GND	B1	GND

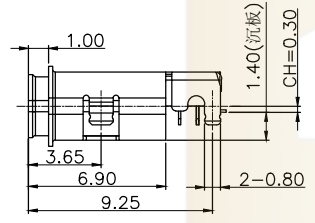
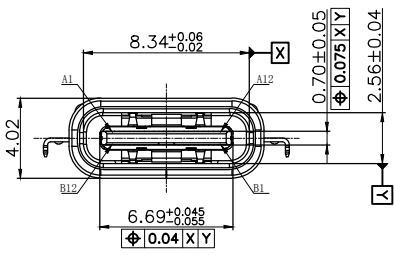
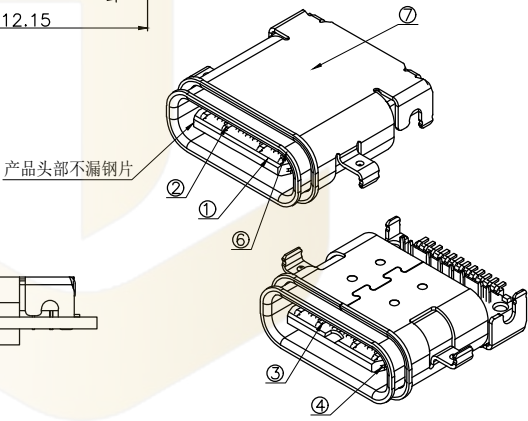
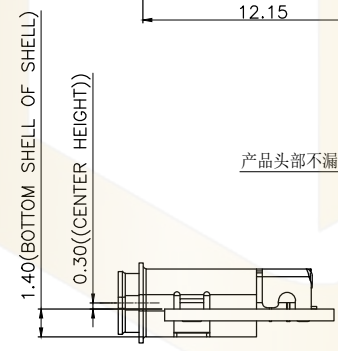
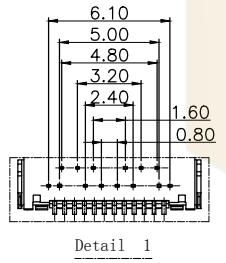
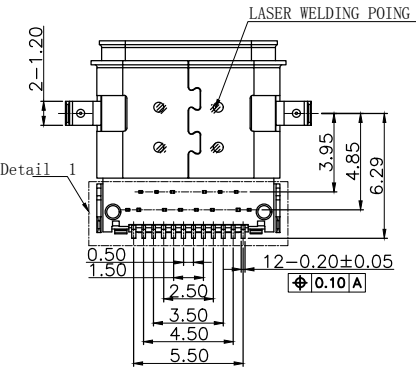

P/N	L	COLOR	额定电流
HC-TYPE C-24P-MM1.4WR-5A-17	9.65mm	黑色	5A

**Ordering Information**

HC-TYPE C - 24P - \* \* \* - \*A - F\* - \* - 17

Pin	Type	Current	Foot	Color
4P	Top Mount (H:1.1)	10A	0.8mm	Black
8P	Top Mount (H:1.1)	5A	0.8mm	White
8P	Mid Mount (H:1.1)	5A	0.8mm	Blue
12P	Center Height (H:2.0)	10A	0.8mm	Green
12P	Center Height (H:2.0)	5A	0.8mm	Orange
12P	Center Height (H:2.0)	5A	0.8mm	Purple
24P	DIP (H:2.0)	5A	0.8mm	Yellow
24P	DIP (H:2.0)	5A	0.8mm	Yellow

TABLE 1:

NO.	PART NAME	QTY	MATERIAL	DESCRIPTION	REMARK
⑧	GLUE WATER	1	EPOXY	BLACK;	---
⑦	Shell-2	1	Stainless steel	NI PLATING;	T=0.20mm
⑥	Shell-1	1	Stainless steel	NI PLATING;	T=0.20mm
⑤	GND PLATE	1	Stainless steel	NI PLATING;	T=0.10mm
④	MID PLATE	1	Stainless steel	---	T=0.15mm
③	Terminal-B	12	铜镍硅合金	Au1u* PLATING;	T=0.12mm
②	Terminal-A	12	铜镍硅合金	Au1u* PLATING;	T=0.12mm
①	Housing	1	HIGH TEMP	Black	---

GENREL TOLERANCE	制 图	
	DIM	TOL
X.X	±0.30	审 核
X.XX	±0.20	批 准
X.XXX	±0.10	APPROVAL
Angle	±3.0°	比 例
		SCALE
		投 影
		Projection

深圳市华灿天禄电子有限公司  
 ShenzhenhuacantianluELECTRONICS CO.,LTD

产品名称	TYPE CF 24P 防水 沉板	版本	A
TITLE	L9.65mm 无弹无柱	REV.	
产品料号	HC-TYPE C-24P-MM1.4WR-5A-17	单 位	mm
PART NO.		页 次	1/3
MATERIAL		SHEET	

# 建议密封方式

## 前后组装方式

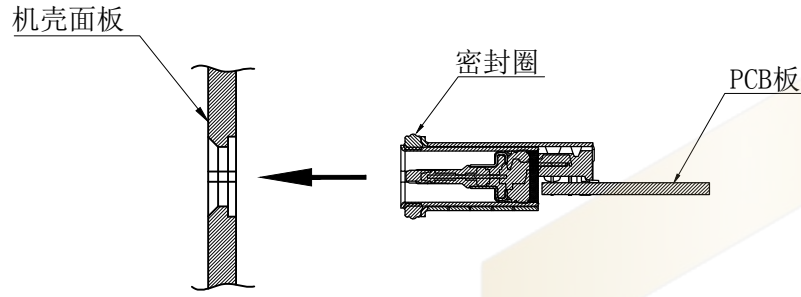

## 建议防水圈规格 (材质硅橡胶)

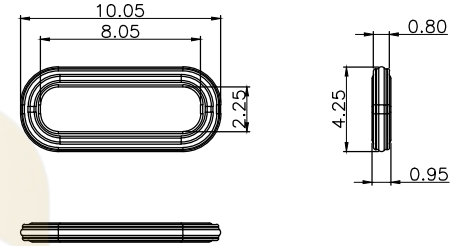

## 组装面板后公母头对插示意图

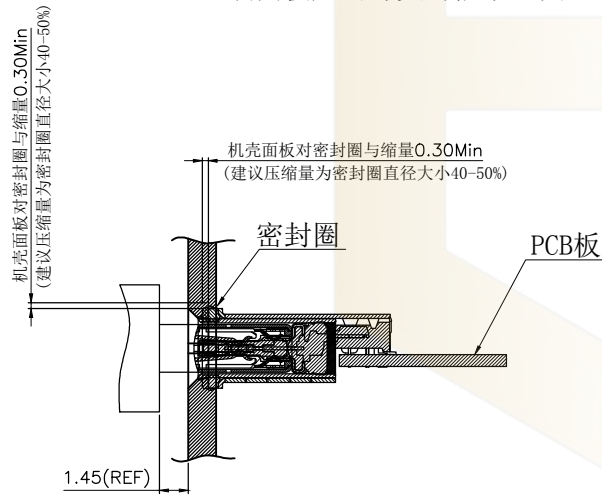

			GENERL TOLERANCE	制图 DRAWING	 <b>深圳市华灿天禄电子有限公司</b> ShenzhenhuaciantianluELECTRONICS CO.,LTD			
			DIM TOL	审核 CHECK				
			X.X ±0.30	批准 APPROVAL	产品名称 TITLE	TYPE CF 24P 防水 沉板 L9.65mm 无弹无柱	版本 REV.	A
1	初版发行		X.XX ±0.20	比例 SCALE	产品料号 PART NO.	HC-TYPE C-24P-MM1.4WR-5A-17	单位 UNITS	mm
序号 No.	变更内容 MODIFY CONTENT	日期 MODIFY DATE	X.XXX ±0.10	投影 Projection	材料 MATERIAL		页次 SHEET	2/3
			Angle ±3.0°					

pcs/box	boxes/Carton	Pcs/Box
700	6	4200

- 包装方式:
- 第一步: 产品使用包装机入包装盘
- (1) 首先将包装盘贴上标签
  - (2) 再将成品按照规定的所示方向摆放于干燥带中进行包装
  - (3) 每盘包装数量700PCS成品
- 第二步: 包装盘入内箱
- (1) 将包装完的包装盘每1盘装入1个真空袋中
  - (2) 每个真空袋中放入一包干燥剂, 并做真空包装处理
  - (3) 拿2盘真空包装好的产品装入1个内箱中
- 第三步: 内箱装外箱
- (1) 将3个内箱共6盘/4200PCS放入外箱中
- 第四步: 外箱封口&贴标签
- (1) 先确认外箱里是否有3个内箱产品
  - (2) 包装完成后使用透明胶带封口, 贴LABEL于规定的位置
- 第五步: 储存&运输
- (1) 储存在通风, 干燥环境; 搬运时轻拿轻放

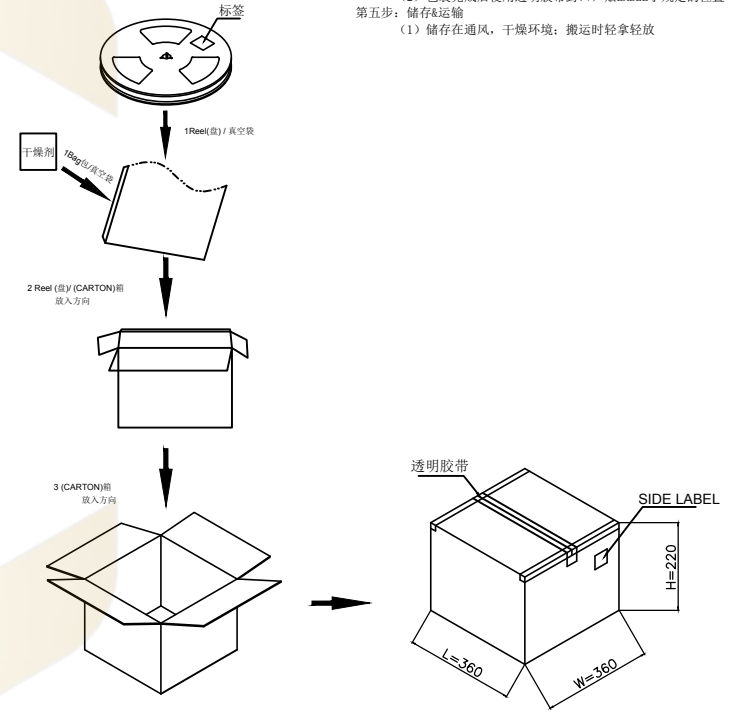
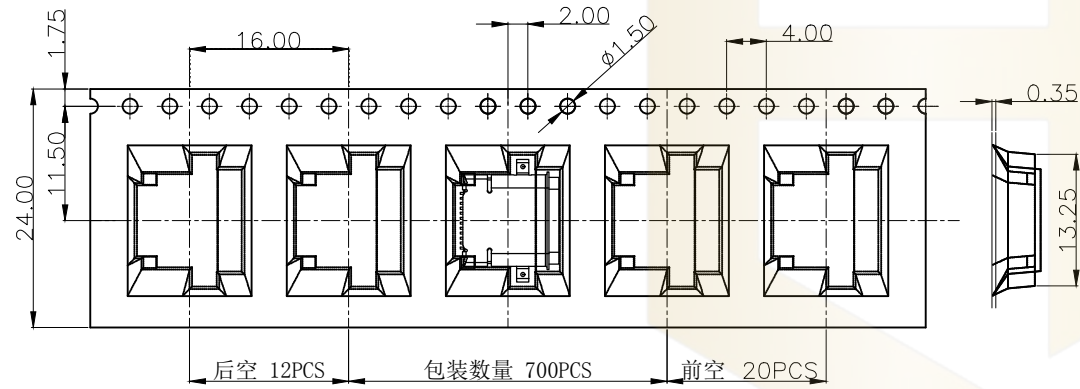
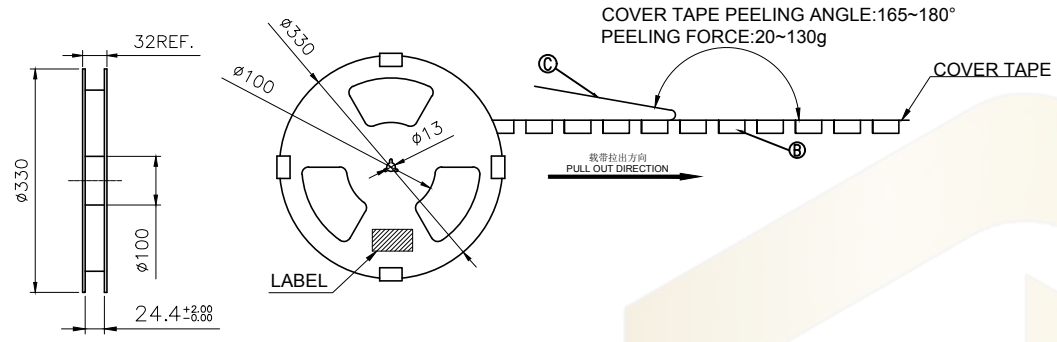

			GENEAL TOLERANCE		制图 DRAWING		深圳市华灿天禄电子有限公司 ShenzhenhuacantianluELECTRONICS CO., LTD			
			DIM	TOL	审核 CHECK		产品名称 TITLE	TYPE CF 24P 防水 沉板 L9.65mm 无弹无柱	版本 REV.	A
			X.X	$\pm 0.30$	批准 APPROVAL		产品料号 PART NO.	HC-TYPE C-24P-MM1.4WR-5A-17	单位 UNITS	mm
			X.XX	$\pm 0.20$	比例 SCALE		材料 MATERIAL		页次 SHEET	3/3
			X.XXX	$\pm 0.10$	投影 Projection					
序号 No.	变更内容 MODIFY CONTENT	日期 MODIFY DATE	Angle		$\pm 3.0^\circ$					